



Richfield City Council Agenda

May 12, 2026 -- 7:00 PM

Richfield Municipal Center
Council Chambers
6700 Portland Avenue South

1. **Call to Order**
2. **Pledge of Allegiance**
3. **Approval of the Agenda**
4. **Approval of Minutes**
 - a. **Meeting Minutes from the City Council Work Session from April 28, 2026.**
 - b. **Meeting Minutes from City Council Regular Meeting from April 28, 2026.**
5. **Open Forum**

Participants can share their comments in person, by voicemail, or email, and may also request to participate virtually. For more information on submitting comments, refer to the Council Agenda and Minutes page on richfieldmn.gov/citycouncil
6. **Proclamations and Presentations**
 - a. **Proclamation Celebrating Jewish American Heritage Month.**
 - b. **Proclamation Recognizing Peace Officers' Memorial Day.**
7. **Consent Calendar**

Consent Calendar contains several separate items, which are acted upon by the City Council in one motion. Once the Consent Calendar has been approved, the individual items and recommended actions have also been approved. No further Council action on these items is necessary. However, any Council Member may request that an item be removed from the Consent Calendar and placed on the regular agenda for Council discussion and action. All items listed on the Consent Calendar are recommended for approval.

 - a. **Approve Disbursements/Claims**
 - b. **Richfield 4th of July Committee celebration license application.**
 - c. **Consider a resolution authorizing the Mayor and City Manager to finalize and execute a Cooperative Construction Agreement with the State of Minnesota Department of Transportation, Contract No. 1061135, for the 73rd Street Trail project completed in 2025.**
 - d. **Consider approval of a request for a new Secondhand Goods Dealer license for EcoAtm, LLC, located at 6540 Penn Avenue South (located in CVS).**
 - e. **Consider a resolution authorizing the Mayor and City Manager to enter into an agreement with the Conservation Corps of Minnesota for installation of rain gardens funded by the Richfield-Bloomington Watershed Management Organization (RBWMO) Grant Program.**
 - f. **Site Plan Approval for conversion of a retail tenant space to a fitness studio at 6503 Nicollet Avenue South.**
 - g. **Consideration of the approval of a Temporary On-Sale Intoxicating Liquor license from the Fourth of July Committee for events scheduled at Veterans Memorial Park, July 4, 2026.**
8. **Consideration of Items, if Any Removed From Consent Calendar**
9. **Public Hearings**
10. **Proposed Ordinances**
 - a. **Consider the first reading of an ordinance amending Subsection 210.01 of the City Code related to City Council salaries for 2027 and 2028.**
11. **Resolutions**
 - a. **Modifying the General Services Post Employment Health Care Savings Plan and Management Post Employment Health Care Savings Plan.**
12. **Other Business**
13. **City Manager's Report**

14. Council Discussion

- a. **Hats off to Hometown Hits**
- b. **Council Liaison Reports**

15. Adjournment

Auxiliary aids for individuals with disabilities are available upon request. Requests must be made at least 96 hours in advance to the City Clerk at 612-861-9739.

Includes Materials - Materials relating to these agenda items can be found in the Council Chambers Agenda Packet book located by the entrance. The complete Council Agenda Packet is available electronically on the City of Richfield website.



CITY COUNCIL MEETING MINUTES

Richfield, Minnesota

City Council Work Session April 28, 2026

ITEM #1	CALL TO ORDER
----------------	----------------------

Mayor Supple called the work session to order on April 28, 2026, at 5:06 p.m, in the Richfield Community Center.

Council Present: Mary Supple, Mayor; Walter Burk, Sean Hayford Oleary, Sharon Christensen, Rori A. Coleman-Woods.

Absent: None.

Staff Present: Sack Thongvanh, Assistant City Manager; Jay Henthorne, Police Chief; Roger Coppa, Interim Fire Chief; Kristin Asher, Public Works Director; Melissa Poehlman, Community Development Director; Karl Huemiller, Recreation Director; and Courtney DesCamps, Senior Analyst.

ITEM #2	ITEM DISCUSSION
----------------	------------------------

a. City Council and Staff Team Building Retreat

Council and staff discussed potential adjustments to Mayor and Council salaries. Discussion included considerations of current compensation levels, historical increases, and data from peer cities. Council directed staff to move forward with updating the ordinance to include a 0% increase in 2027 and a 0% increase in 2028 for Mayor and Council salaries. No formal action was taken.

Council and staff discussed staffing levels and succession planning.

Council and staff reviewed the existing code of conduct. Discussion focused on expectations for roles, communication, and maintaining professional standards. Direction was provided to continue reviewing and refine as needed.

ITEM #3	ADJOURNMENT
----------------	--------------------

Mayor Supple adjourned the work session at 6:02 p.m.

Date Approved: May 12, 2026

Mary B. Supple
Mayor

Courtney DesCamps
Senior Analyst

Sack Thongvanh
Assistant City Manager

DRAFT



CITY COUNCIL MEETING MINUTES

Richfield, Minnesota

Council Regular Meeting

April 28, 2026

ITEM #1	CALL TO ORDER
----------------	----------------------

The meeting was called to order by Mayor Supple at 7:00 p.m. on April 28, 2026, in the Council Chambers.

Council Present: Mary Supple, Mayor; Walter Burk, Sean Hayford Oleary, Sharon Christensen, and Rori A. Coleman-Woods.

Staff Present: Sack Thongvanh, Assistant City Manager; Sam Ketchum, City Attorney; and Michelle Friedrich, City Clerk.

Staff Excused: Katie Rodriguez, City Manager.

Guests: None.

ITEM #2	PLEDGE OF ALLEGIANCE
----------------	-----------------------------

Mayor Supple led the Pledge of Allegiance.

ITEM #3	PRESENTATIONS
----------------	----------------------

- a. STEM School Choir

Mayor Supple introduced the STEM School Choir. The STEM School Choir performed several songs for the Council and City of Richfield residents.

ITEM #4	APPROVAL OF THE AGENDA
----------------	-------------------------------

MOTION: made by Council Member Coleman Woods, seconded by Council Member Burk to approve the agenda as presented.

Voting Aye: Mayor Supple, Council Member Burk, Council Member Hayford Oleary, Council Member Christensen, and Council Member Coleman-Woods.

Motion carried: 5-0

ITEM #5	APPROVAL OF MINUTES
----------------	----------------------------

Mayor Supple noted a clerical error was corrected for item 12a of the April 14 Regular Meeting Minutes. Mayor Supple noted Council received one email comment for Open Forum and that the email would be included with the April 28 Regular Meeting Minutes.

a. Approval of the Minutes

MOTION: made by Council Member Coleman-Woods, seconded by Council Member Hayford Oleary to approve the minutes of the (1) City Council Work Session from April 14, 2026, and (2) Regular Meeting from April 14, 2026, with the clerical revision to item 12a.
 Voting Aye: Mayor Supple, Council Member Burk, Council Member Hayford Oleary, Council Member Christensen, and Council Member Coleman-Wood
Motion carried: 5-0

ITEM #6	OPEN FORUM
----------------	-------------------

Mayor Supple noted the process for individuals wishing to speak during Open Forum and reviewed the three-minute time limit for public comments and explained the use of time warning cards to alert the speaker when their time is almost expired. Instructions were given for speakers to state their name and city of residence before speaking.

Two residents addressed the Council during the Open Forum opportunity.

Birgit Johnson, Richfield resident, thanked the sustainability commission for allowing their comments regarding Vets Park black-winged heron viewing platform, and asked Council to be cognizant of costs. Ms. Johnson commented on the work session from the April 14 presentation, and opined on gun safety.

Heidi Gaibor, Richfield resident, thanked the STEM choir for performing at the Council meeting tonight.

ITEM #7	PROCLAMATIONS AND PRESENTATIONS
----------------	--

a. Proclamation celebrating Asian and Pacific American Heritage Month.

Mayor Supple read the proclamation recognizing Asian and Pacific American Heritage month. The proclamation was received by Valerie Hurst-Baker.

ITEM #7	CONSENT CALENDAR
----------------	-------------------------

Acting City Manager Thongvanh presented the consent calendar.

a. Approve Disbursements/Claims

U.S. BANK	Thru 4-24-2026
A/P Checks/ETF's: (4-4-2026 through 4-17-2026)	\$1,148,545.84
Payroll (4-24-2026)	\$1,121,462.23
TOTAL	\$2,270,008.07

- b. Approval of the bid tabulation and authorize the Mayor and City Manager to execute a contract with Concrete Idea, Inc., for the Safe Routes to School Sheridan Hills Elementary sidewalk project in the amount of \$429,153.25 and authorize the City Manager to approve contract changes up to \$175,000 without further City Council consideration.
- c. Adoption of a resolution for reimbursement of certain expenditures from the proceeds of street reconstruction bonds and utility bonds to be issued by the City for the Penn Avenue (CSAH 32) Reconstruction Project.

**RESOLUTION NO. 2026-12419
DECLARING THE OFFICIAL INTENT OF THE CITY OF RICHFIELD TO REIMBURSE CERTAIN EXPENDITURES FROM THE PROCEEDS OF BONDS TO BE ISSUED BY THE CITY WITH RESPECT TO THE PENN AVENUE RECONSTRUCTION PROJECT**

- d. Adoption of a resolution authorizing execution of Minnesota Department of Transportation (MnDOT) Agreement No. 1062789 for the disbursement of state general obligation bond funds for the Sheridan Hills Safe Routes to School project.

**RESOLUTION NO. 2026-12420
AUTHORIZING EXECUTION OF MINNESOTA DEPARTMENT OF TRANSPORTATION (MNDOT) AGREEMENT NO. 1062789 FOR THE DISBURSEMENT OF STATE GENERAL OBLIGATION BOND FUNDS FOR THE SHERIDAN HILLS SAFE ROUTES TO SCHOOL PROJECT**

- e. Consider approval of an Encroachment Agreement between the City of Richfield and Herspace, LLC, allowing the property owner at 6440 Nicollet Avenue to maintain an existing private parking lot and commercial sign within public right-of-way.

MOTION: made by Council Member Hayford Oleary, seconded by Council Member Christensen, to approve consent calendar items 7a-e as presented.

Voting Aye: Mayor Supple, Council Member Burk, Council Member Hayford Oleary, Council Member Christensen, and Council Member Coleman-Woods.

Motion carried: 5-0

ITEM #8	CONSIDERATION OF ITEMS, IF ANY, REMOVED FROM CONSENT CALENDAR
----------------	--

None.

ITEM #9	PUBLIC HEARINGS
----------------	------------------------

None.

ITEM #10	PROPOSED ORDINANCES
-----------------	----------------------------

None.

ITEM #11	RESOLUTIONS
-----------------	--------------------

None.

ITEM #12	OTHER BUSINESS
-----------------	-----------------------

None.

ITEM #13	CITY MANAGER’S REPORT
-----------------	------------------------------

Acting City Manager Thongvanh noted there was nothing to report this week.

ITEM #14	COUNCIL DISCUSSION
-----------------	---------------------------

a. Hats off to Hometown Hits.

Council Member Hayford Oleary noted the Richfield Foundation fundraiser event date has been rescheduled to the fall, with Council indicating a tentative October 8 date to be confirmed. Council Member Hayford Oleary provided an update related to the Transportation Commission, noting the upcoming meeting will include continued discussions on Penn Avenue, ongoing community input and a collaborative planning process.

Council Member Christensen reported an art exhibit featuring students from Richfield High School will be held at the community center next Thursday from 4:00–5:00 p.m., followed by a reception. Council Member Christensen added the exhibit will include a wide variety of artwork, such as paintings, drawings, and sculptures, displayed throughout the upper level and will remain on display for an extended period after the event.

Council Member Coleman-Woods acknowledged the Sustainability Commission and its efforts around Earth Day, Compost Day on May 1, and an electronics recycling and paper shredding event at the ice arena parking lot on May 14.

Mayor Supple recognized Council Member Hayford Oleary for testifying before the Senate Transportation Committee on behalf of Richfield. Mayor Supple highlighted a donation opportunity, supported by the Richfield Community Safety Network, which is seeking \$25,000 in community donations to unlock a \$400,000 matching gift, with a deadline of May 6. Mayor Supple noted an upcoming Northstar Therapy Animals event on April 30 from 4:00–7:00 p.m. at the Mall of America Rotunda, promoting community involvement and support for therapy animal programs. Mayor Supple expressed appreciation for the STEM school choir’s performance.

b. Council Liaison Reports

Brief reports noted above in Hats off to Hometown Hits.

ITEM #15	ADJOURNMENT
-----------------	--------------------

MOTION: made by Council Member Coleman-Woods, seconded by Council Member Hayford Oleary to adjourn the meeting at 7:35 p.m.

Voting Aye: Mayor Supple, Council Member Burk, Council Member Hayford Oleary, Council Member Christensen, and Council Member Coleman-Woods.

Motion carried: 5-0

Date Approved: May 12, 2026

Mary Supple
Mayor

Michelle Friedrich
City Clerk

Sack Thongvanh
Acting City Manager

DRAFT

From: [Michelle Friedrich](#)
To: [Sack Thongvanh](#)
Cc: [Mark McKinley](#); [Karl Huemiller](#); [Katie Rodriguez](#); [Mary Supple](#)
Bcc: [Sean Hayford Oleary](#); [Sean Hayford Oleary](#); [Sharon Christensen](#); [Walter Burk](#); [Rori Coleman-Woods](#); [Rori Woods](#)
Subject: FW: Public Comment Submission for April 28
Date: Monday, April 20, 2026 8:20:00 AM
Attachments: [image001.png](#)

Good Morning Mayor and Council,

Please see the email trail below for a public comment received for the wildlife viewing platform.



Michelle Friedrich (she/her/hers)
City Clerk
6700 Portland Ave S., Richfield MN 55423
Tel: (612) 861-9739 | Fax: (612) 861-9715
mfriedrich@richfieldmn.gov

From: No Reply <noreply@civicplus.com>
Sent: Sunday, April 19, 2026 2:27 PM
To: Michelle Friedrich <MFriedrich@richfieldmn.gov>
Subject: Public Comment Submission

Submitted by: Pamela S
Email Address: jpkitty111@gmail.com

User comment: A platform viewing area by the Black-crowned Night Heron island will not be useful to people and it will only disturb the wildlife that seeks sanctuary on the island. What a huge waste of money.



Proclamation of the City of Richfield

WHEREAS, Jewish American Heritage month celebrates the culture, heritage, and traditions of Jewish Americans and all their achievements and contributions to Richfield, Minnesota, the United States, and the world; and

WHEREAS, 2026 marks the 46th annual celebration of achievements and contributions by Jewish Americans, starting with the establishment of Jewish American Heritage Week in 1980 and expanded upon in 2006, when President George W. Bush and Congress ordered that the country observe an annual Jewish American Heritage Month each May; and

WHEREAS, over 7.5 million Jewish Americans have contributed to the many aspects of American society including arts, education, sports, law, medicine, and public service, and more; and

WHEREAS, Jewish Americans have fought honorably, a number earning the Medal of Honor, to ensure our freedom by serving in colonial militias, in the American Revolution, and all American military conflicts since the establishment of the United States; and

WHEREAS, Richfield is home to important Jewish cemeteries including; the Minneapolis Jewish cemetery founded in 1890, the United Hebrew Brothers Cemetery, Gemelus Chesed Cemetery, and the B'nai Emet Cemetery; and

WHEREAS, as we celebrate the rich heritage of the Jewish American Community, we recognize tireless work to strengthen the promise of religious freedom and civil rights, by joining together with all faiths to reject ignorance and intolerance, teach empathy and compassion, and root out hatred wherever it exists; and

WHEREAS, the city of Richfield is proud of the people, community, and businesses of Jewish Americans. We look forward to the continuing success of Jewish Americans in our community; and

WHEREAS, the Richfield Human Rights Commission supported a proclamation celebrating Jewish American Heritage Month at its April 7th, 2026 meeting;

Now, THEREFORE, I, Mary Supple, mayor of Richfield, on behalf of the Richfield City Council, do hereby proclaim the month of May 2026 as Jewish American Heritage Month in the City of Richfield and call on the people of Richfield to continue to observe this month with appropriate programs, activities, and ceremonies, and continue to honor the contributions of Jewish Americans throughout the year.

PROCLAIMED this 12th day of May, 2026.

Mary B. Supple, Mayor



Proclamation of the City of Richfield

WHEREAS, the people of this community wish to join with the entire nation in recognizing the valor, bravery and dedication to duty of our law enforcement officers; and,

WHEREAS, President John F. Kennedy signed a proclamation which designated May 15 as Peace Officers Memorial Day and the week in which that date falls as Police Week, and declared that all flags of the United States be flown at half-staff on that date; and,

WHEREAS, 363 new names will be added to the National Monument in 2026; and,

WHEREAS, this City of Richfield recognizes that our own law enforcement officers, who day after day, hour by hour, serve, not only as law enforcement agents of this City to protect life and property, but are indeed Friend, Neighbor and Guardian.

NOW, THEREFORE, I, MARY SUPPLE, Mayor of the City of Richfield, do hereby proclaim:

**May 10-16, 2026, as NATIONAL POLICE WEEK and
May 15, 2026, as PEACE OFFICERS' MEMORIAL DAY
IN THE CITY OF RICHFIELD**

And call upon every citizen to honor and memorialize those law enforcement officers in this country and city who have lost their lives in the defense of our homes, families or property, and to join with our law enforcement officers in acknowledging our thanks for their service, valor and dedication to duty and our pledge of continued support for their unending war on crime and promotion of safety through enforcement in the year ahead.

PROCLAIMED the 12th day of May, 2026.

Mary Supple, Mayor



Report Prepared By:
Jill Murphy, Recreation Program Manager

Department Director:
Karl Huemiller, Recreation Director

Item for Consideration:
Richfield 4th of July Committee celebration license application.

EXECUTIVE SUMMARY

City Code identifies the importance of community celebrations, such as the 4th of July, and designating City lands to be used for community celebrations. Understanding that significant planning goes into large events, City Code outlines a process for designating non-profit organizations to plan and coordinate community celebration activities.

For more than 40 years, the Richfield 4th of July Committee has worked with City staff to coordinate the 4th of July celebration. They have submitted an application for a celebration license to plan the July 4, 2026, festivities. The activities for 2026 are proposed to take place on Saturday, July 4, 2026.

RECOMMENDED ACTION

By Motion: Grant the Richfield 4th of July Committee a celebration license and waive the \$5,000 fee associated with the license.

HISTORICAL CONTEXT

Following the celebration on July 4, 2019, the Richfield 4th of July Committee took a four-year hiatus. In 2024, they planned a 2-day event which was interrupted by severe weather. In 2025, they planned a 2-day event. This year, they are planning a 1-day event.

EQUITABLE OR STRATEGIC CONSIDERATIONS OR IMPACTS

The 4th of July celebration is an event that brings the community together and provides free activities for residents on July 4, 2026.

POLICIES (RESOLUTIONS, ORDINANCES, REGULATIONS, STATUTES, ETC.)

City Code 850. defines a community celebration. Section 850.09 outlines the process for applying for a community celebration license.

850.09. - Community celebration: license

Subdivision 1. General rule. It is a violation of this section for any individual or entity, other than the City, to conduct a community celebration or any of the celebration activities without having first obtained a license to do so. The City may license nonprofit corporations to conduct community celebration activities.

Subd. 2. Application. A nonprofit corporation wishing to conduct celebration activities

in connection with a designated community celebration shall make application to the City Manager. The application shall contain the following information together with any additional information required by the City Manager:

- (a) Name of corporation;
- (b) Copy of articles and bylaws;
- (c) Detailed activity plan (DAP) describing completely time, location and nature of all proposed activities;
- (d) If the DAP includes the sale of concessions, a statement of the uses to which the proceeds will be put.

Subd. 3. Review of application. The Manager shall review the application and may refer it to any department for review and comment. Following review, the City Manager shall make a report and recommendation to the City Council.

Subd. 4. Council action. The City Council shall consider the application, the recommendation of the City Manager and may consider any other information it deems appropriate. Following its review, the council may either grant or deny the license. In granting the license, the council may modify the DAP and place such terms and conditions upon the license as it determines advisable.

Subd. 5. License fee. The license fee shall be \$5,000.00 which must be paid prior to the issuance of the license. The council may, in its discretion waive all or part of the fee.

CRITICAL TIMING ISSUES

The 4th of July Committee requires a celebration license prior to finalizing the celebration's activities.

FINANCIAL IMPACT

City staff from Fire, Public Safety, Public Works, and Recreation Services provide support to the 4th of July celebration.

LEGAL CONSIDERATIONS

None.

ALTERNATIVE RECOMMENDATION(S)

By Motion: Grant the Richfield 4th of July Committee a celebration license and charge the \$5,000 fee associated with the license.

ATTACHMENTS

1. Celebration Permit 4th of July 2026

**CITY OF RICHFIELD
6700 PORTLAND AVENUE SOUTH
RICHFIELD, MN 55423**

APPLICATION FOR A COMMUNITY CELEBRATION LICENSE

FEE: \$ 5000

Definition – “Community Celebration” or “celebration” means Independence Day and any other event designated by resolution of the city council as a community celebration.

Name of Event: Richfield 4th of July Celebration

Location of Event: Veteran's Park : Parade route that is TBD

Date of Event: July 4, 2020

Name of Person in charge of event: (Steve) Schneeberger

Address: 10800 Lyndale Ave S, Suite 324, Bloomington, MN 55420

Cell Phone: 612-581-7313

Email: steveschneeberger@gmail.com

Sponsoring Organization/Corporation: Richfield 4th of July Committee, Inc.

All applicants must submit the following with their application:

1. A Detailed Activity Plan (DAP) describing the time, location and nature of all proposed activities. If the DAP includes the sale of concessions, a statement of the uses to which the proceeds will be put must also be included.
2. Copy of any articles and bylaws of your organization or corporation.

Applicant is responsible for all other appropriate licenses and permits, including but not limited to electrical, liquor and food.

For any event in which food will be prepared and served, it will be necessary for the person in charge to complete the appropriate food license applications. The City of Richfield contracts with the City of Bloomington for all food inspections and your food plans must be discussed with Bloomington Environmental Health prior to your event taking place.

LICENSE AGREEMENT FOR COMMUNITY CELEBRATION

This License Agreement for Community Celebration ("Agreement") is made this 10th day of March, 2026, by and between the City of Richfield, a municipal corporation located in Minnesota ("City") and Richfield 4th of July Committee, Inc., a non-profit corporation located in Bloomington, MN ("Licensee").

RECITALS

WHEREAS, Licensee has requested a community celebration license from the City to host a community celebration on July 4, 2026 ("Event");

WHEREAS, the City has agreed to grant the community celebration license subject to Licensee executing this Agreement; and

NOW, THEREFORE, in consideration of the City's actions described above, the parties agree as follows:

AGREEMENT

1. Licensee agrees to comply with all laws, ordinances, and requirements of the City and any other governmental agencies regarding the Event. Prior to the Event, Licensee shall complete a license application, pay the license fee, and submit a Detailed Action Plan and any other documentation required by the City. Licensee shall also obtain all other required licenses and approvals for the Event, including any required liquor licenses.
2. Prior to the Event, Licensee shall provide the City with any necessary certificate of insurance evidencing that it has commercial general liability and liquor liability insurance (if applicable) for the event, in coverage amounts acceptable to the City Attorney, and documentation that the City is named as an additional insured with respect to these policies.
3. Licensee agrees to defend, indemnify and hold harmless the City, its officers, agents, and employees from any claim for personal injury, property damage or death, occasioned by or arising out of the conduct of the licensed activities.
4. Licensee shall release and discharge the City, its officers, agents, and employees from any claim or cause of action occasioned by or arising out of any action taken by the City to close all or part of the celebration site and terminate all or part of the celebration activities in order to protect or restore order or end or prevent breaches of the peace or public order,
5. Licensee shall remove all rubbish and litter from the celebration site and restore the areas to their prior condition and appearance not later than 24 hours following the conclusion of the licensed activities.

IN WITNESS OF THE ABOVE, the parties have caused this Agreement to be executed on the date and year written above.

CITY OF RICHFIELD

LICENSEE

By: _____

By:  _____

Its: _____

Its: President _____

By: _____

Its: _____

**Detailed Activity Plan (DAP)
for
Richfield 4th of July Committee, In.**

Date of Event: July 4, 2026

Event Details:

Veteran's Park – Honoring All Veteran's Memorial
10:00 a.m. – Wreath laying ceremony

Parade – Route is to be determined between the City and Committee
4:00 p.m.

Veteran's Park – Bandshell
5:00 p.m. to 10:00 p.m. – Alcohol sales and serving by Luce Line Brewing
10:00 p.m. – Fireworks
Entertainment and Food Trucks will be present. These are being organized and provided by the City of Richfield.

0-63, 856

77

2-199

RICHFIELD 4TH OF JULY COMMITTEE, INC.

ARTICLES OF INCORPORATION

ARTICLE I

NAME

The name of this corporation is "RICHFIELD 4TH OF JULY COMMITTEE, INC.," and its principal place of service and its registered office shall be in the City of Richfield, County of Hennepin, State of Minnesota.

✓
✓
✓

ARTICLE II

PURPOSE

Section 1. The primary purpose of this corporation is to advance and promote the observance of Independence Day in the City of Richfield, Minnesota. In so doing it is the objective of the corporation to provide a celebration which can provide patriotic expression, family participation, amusement, community cohesiveness and homecoming.

Section 2. The general purposes of this corporation are:
(1) to advance and promote the civic betterment and general welfare of the City of Richfield, County of Hennepin and State of Minnesota and exploit the natural resources and opportunities of the community, its trade and commerce and its religious and educational life, by providing recreation and entertainment for all classes and by improving the physical moral, and mental

WILLIAMS

condition of its people; (2) to advance the commercial, economic, social, musical and athletic interests within the community; (3) to create a spirit of good will and friendliness among the people of this community and those living elsewhere in the state and nation, and to expand commercial, economic and social relationships in the general trade area of the community; (4) to provide a program of sports and attractions for the common interest of the people of the community; (5) to promote, produce, and stage such events and attractions as shall appeal to the community and shall attract guests and visitors thereto; and (6) to serve as a nonprofit corporation under the provisions of the Minnesota Nonprofit Corporation Act.

ARTICLE III

POWERS

Section 1. The corporation is a membership corporation and has the power, either directly or indirectly, either alone or in conjunction or cooperation with others, to do any and all lawful acts and things and to engage in any and all lawful things and to engage in any and all lawful activities which may be necessary, useful, suitable, desirable or proper for the furtherance, accomplishment, fostering, or attainment of the purposes for which the corporation is organized, and to aid or assist other organizations whose activities are such as to further, accomplish, foster, or to attain such purposes.

Section 2. It has the power to acquire and receive by purchase, gift, grant, devise, or otherwise any property, real or

personal, and to hold, invest and to hold, sell, convey, assign, loan, lease or otherwise transfer and use the same for the purposes set forth herein.

Section 3. It has the power to raise money by the payment of dues or the solicitation of subscriptions or contributions in the furtherance of the purposes herein stated and to cooperate with and aid and assist all affiliations with any individuals, societies or associations, corporations or institutions whose purpose are altogether or in part similar to this organization.

Section 4. The corporation has the power to exercise any and all of the powers and authorities granted to, or permitted to be exercised by, nonprofit corporations under the provisions of the Nonprofit Corporation Act as said Act now exists, or as such an Act may hereafter be adopted, or as they may be amended from time to time.

Section 5. Notwithstanding any other provisions of these articles of incorporation, the corporation shall not conduct or carry on any activities not permitted to be conducted or carried on by an organization exempted under Section 501(c)(3) of the Internal Revenue Code and the regulations thereunder amended from time to time.

ARTICLE IV

DURATION AND LIMITATION

This corporation shall have perpetual existence and shall have no capital stock. This corporation shall not afford

pecuniary gain, incidentally or otherwise, to its members, and no part of the net income of the corporation and no part of the net assets of the corporation shall inure to the benefit of any member or individual or to any corporation organized for profit, either during the operation of the corporation, or upon dissolution of the corporation.

ARTICLE V

MEMBERSHIP

The membership of this corporation shall consist of individuals, corporations or other entities who are interested in the promotion of the purposes herein set forth and who subscribe to such terms and conditions as may be provided in the by-laws.

ARTICLE VI

BOARD OF DIRECTORS AND OFFICERS

Section 1. The board of directors shall be as established in the by-laws of this corporation, and the by-laws shall prescribe the number, term of office, powers, authority and duties of directors.

Section 2. The officers of the corporation shall be as established in the by-laws and shall hold such terms and have such authority as prescribed in the by-laws, or, in the absence of such prescription, as the board of directors determines.

Section 3. The name and address of each of the directors of this corporation at the time of the adoption of these articles of

0.63, 660

incorporation, and the year in which his or her term as a director of this corporation expires, are as follows:

<u>Name</u>	<u>Address</u>	<u>Year in Which Term Expires</u>
Paul M. Kaiser	7233 Sheridan Avenue South Richfield, MN	1985
Ethel Naslund	7114 Logan Avenue South Richfield, MN	1986
Joanne C. Wilmes	6827 - 16th Avenue South Richfield, MN	1985
Sharon Kosek	6530 Bloomington Avenue South Richfield, MN	1986
George Evans	6921 Columbus Avenue South Richfield, MN	1986
Bob Houlton	7545 - 10th Avenue South Richfield, MN	1986
Carole Memmel	6507 Humboldt Avenue South Richfield, MN	1985
Phoebe Nelson	6805 Knox Avenue South Richfield, MN	1986
Theresa Kassa	7638 Upton Avenue South Richfield, MN	1985
Ronald Kassa	7638 Upton Avenue South Richfield, MN	1985

The term of office of each director shall be until the annual meeting of this corporation in the year in which his or her term expires and until his or her successor shall have been selected or elected in the manner provided for in the by-laws of this corporation and he or she shall have qualified.

ARTICLE VII

INCORPORATORS

The names and addresses of the incorporators of this corporation are the persons named and the addresses given in the foregoing Article VI, Section 3.

ARTICLE VIII

NO PERSONAL LIABILITY

Members, directors, and officers of this corporation shall not be personally liable for the payment of any debts or obligations of this corporation nor shall any of the property of the members, directors, and officers be subject to the payment of the debts or obligations of this corporation.

ARTICLE IX

MEETINGS

Section 1. The annual meeting of the members of the corporation shall be held at such time and place as the board of directors may determine, within forty-five (45) days following the end of the fiscal year of the corporation as established in the by-laws. Special meetings of the members shall be called and held as prescribed in the by-laws.

Section 2. Annual, regular or special meetings of the board of directors shall be called and held as prescribed in the by-laws of the corporation, or, in the absence of such prescription, as the board of directors may determine.

ARTICLE X

BY-LAWS

The board of directors, by a two-thirds vote of the directors who are present and entitled to vote, may, at any meeting where notice of the meeting and the proposed amendment has been given, adopt, alter or amend the By-Laws for the government of the corporation and the management of its affairs as are in conformance with these articles.

ARTICLE XI

AMENDMENT OF ARTICLES OF INCORPORATION

The articles of incorporation of this corporation may be amended at any annual meeting of the members of the corporation by a majority vote of those present and voting, or at any special meeting by a two-thirds vote of the members present and voting; provided, however, that notice of the meeting of members, stating the purpose, shall be given to each member entitled to vote on the proposed amendment, and to each officer and director regardless of his voting rights.

ARTICLE XII

DISSOLUTION

This corporation may be dissolved in accordance with the laws of the State of Minnesota. Upon dissolution of this corporation and after the payment of all liabilities and obligations of this corporation and all costs and expenses incurred by it in connection with such dissolution, any remaining assets shall be

0-63, 663

distributed to the City of Richfield to be used exclusively for the purposes as defined in Article II hereof.

IN WITNESS WHEREOF, we have hereunto set our hands this 28th day of December, 1984.

Paul M. Kaiser
Paul M. Kaiser

Ethel Naslund
Ethel Naslund

Joanne Wilmes
Joanne Wilmes

Sharon Kosek
Sharon Kosek

George Evans
George Evans

Bob Houlton
Bob Houlton

Carol Memmel
Carol Memmel

Phoebe Nelson
Phoebe Nelson

Theresa Kassa
Theresa Kassa

Ronald Kassa
Ronald Kassa

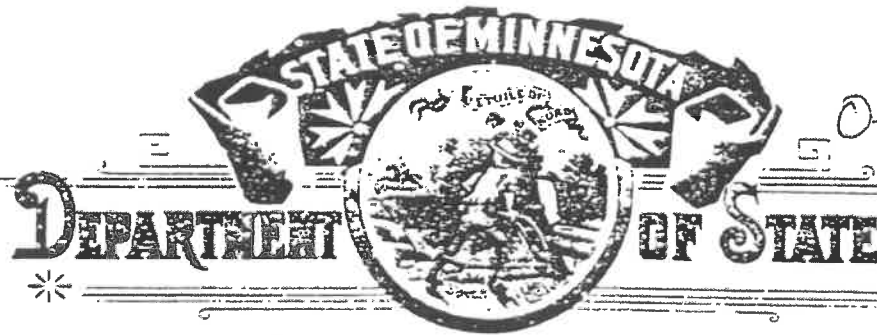

To All To Whom These Presents Shall Come, Greeting:

Whereas, Articles of Incorporation, duly signed and acknowledged under oath, have been recorded in the office of the Secretary of State, on the 10th day of January, A. D. 1985 for the incorporation of

RICHFIELD 4TH OF JULY COMMITTEE, INC.

under and in accordance with the provisions of the Minnesota Nonprofit Corporation Act, Minnesota Statutes, Chapter 317;

Now, Therefore, by virtue of the powers and duties vested in me by law, as Secretary of State of the State of Minnesota, I do hereby certify that the said RICHFIELD 4TH OF JULY COMMITTEE, INC.

is a legally organized Corporation under the laws of this State.

Witness my official signature hereunto subscribed and the Great Seal of the State of Minnesota hereunto affixed this tenth day of January in the year of our Lord one thousand nine hundred and eighty-five

John Anderson Grove
Secretary of State.

Richfield 4th of July Committee, Inc. By-Laws

Article I

General Membership

Section 1

- Membership in the Richfield 4th of July Committee, Inc. (hereafter referred to as the “Corporation”) consists of those persons and corporations who: a) complete an application for Membership, b) are residents of the City of Richfield or have business or other close associations with the City of Richfield and c) agree to comply with the Articles of Incorporation and By-Laws of the Corporation and any rules and regulations adopted by its Officers.

Section 2

- Membership applications shall be acted upon by the Corporation, who shall have the power to grant or deny such applications.

Section 3

- Initial Memberships shall be for a probationary period of one (1) year. After initial Membership period, Membership will be automatically renewed indefinitely. Membership may be terminated by the Members for failure to comply with the rules and regulations, Articles of Incorporation, or By-Laws of the Corporation. Officers shall be elected for a one (1) year term and must be Members.

Section 4

- A Member may withdraw from Membership at any time, upon written request and with thirty (30) days’ notice. Such notice shall become effective immediately upon receipt of a request to withdraw by the Secretary of the Corporation.

Section 5

- Memberships may be individual or corporate. A member corporation may designate a person to act as its representative on the Corporation and to represent that corporation at Committee meetings. Such a designated representative of a member corporation shall be eligible to serve as an Officer. Each Member may only have one (1) vote, be it either individual or corporate. Memberships may be for a Member or a Volunteer, as defined previously. Each elected Member is allowed one (1) vote at Committee meetings. Volunteers are not allowed to vote. There shall be no voting by proxy, unless approved by the President.

Section 6

- Memberships shall not be transferrable.

Article II

Meetings and Members

Section 1

- The annual meeting of the Members of the Corporation shall be held within sixty (60) days following the end of the fiscal year of the Corporation at a time and place to be determined by the Officers.

Section 2

- At least fifteen (15) days before the date of the annual meeting, the Corporation shall email a notice of the meeting to each member at his/her email address, as shown on the Corporation Roster. The annual meeting may also be published in a Richfield community publication. Method of communication used to notify Members of the annual meeting is at the discretion of the Officers.

Section 3

- Special meetings of the Membership of the Corporation may be called by the Officers at such a time and place as the President may designate. Notice to the Members should be given as provided in Article II, Section 2. The notice shall be transacted at a special meeting.

Section 4

- Regular meetings shall be held on the third (3rd) Thursday of each month, August through April and the first (1st) and third (3rd) Thursdays in May and June, unless voted on by the Members.

Section 5

- At any annual or special meeting of the Membership of the Corporation, each Member present shall be entitled to one (1) vote on all matters coming up before The Corporation. There shall be no voting by proxy, unless approved by the President.

Article III

General Management

Section 1

- The general management and control of the business and affairs of the Corporation shall be vested in the Members. Members shall be elected initially to a one (1) year term, indefinitely after the initial term has been completed.

Section 2

- Members of the Corporation shall be elected following receipt of their application.

Section 3

- The Members may appoint Volunteers, as they may deem them necessary to serve. Volunteers shall serve one (1) year terms and may be reappointed annually. Volunteers shall be eligible to be elected as Members of the Corporation.

Section 4

- A quorum will consist of a majority of the current, active Members of the Corporation at annual meetings. A quorum is not required at the regular monthly meetings.

Section 5

- Regular attendance at all regular monthly meetings is expected of all Members and Officers. When any Member is unexcused at more than three (3) meetings within any given fiscal year, the Members will meet to evaluate the continuance of that Member's Membership.

Section 6

- Members shall receive no monetary compensation for their duties other than reimbursement for actual and necessary expenses, as authorized by the President.

Section 7

- Any vacancy that occurs on Officer or Committee Chairs during any term shall be filled by the Members to complete the remainder of the unfinished term.

Section 8

- Members may be removed at any time, for any cause by a three-fourths (3/4) vote of all other Members. Members up for removal will be advised as to the Members' concern(s) prior to the meeting in which their continued Membership will be voted on and will be permitted to attend and defend their position. In the event of such a removal, the Members may, at the same meeting, appoint a successor to the removed Member(s) to complete the unfinished term(s) of the removed Member(s). Any Member that is removed must turn over all materials used in regard to their Membership with the Corporation to an Officer.

Section 9

- The Officers will propose recommendations and the Members shall have the power to make and adopt such rules, regulations and policies as it deems advisable, consistent with law, Articles of Incorporation and By-Laws of the Corporation, for the management, administration and regulation of the affairs of the Corporation. In the event a stalemate occurs, the vote will go to the Members at the next regular monthly meeting where majority vote of the Members will decide.

Section 10

- The Members may cause annual audits of the financial records of the Corporation to be made at the end of each fiscal year. An independent accountant must conduct such an audit. The results of such audit shall be reported to the Members of The Corporation at its next (ensuing) regular monthly meeting.

Section 11

- The Corporation may, at its own expense, secure a fidelity bond or insurance to protect the funds of the Corporation from misappropriation or loss as a result of the conduct of the Members or others.

Section 12

- Check signing shall be performed as follows:
 - All checks require President's approval before being issued by the Bookkeeper.
 - The President and the Bookkeeper shall be designated as signors.
 - The Board may approve a third signor, as they deem necessary.

Section 13

- Contract signing shall be performed as follows:
 - All contracts require approval from an Officer, verbal or written.
 - President approval is necessary for all contracts beyond Corporation-approved budgets.

Article IV

Meeting of Members

Section 1

- A regular meeting of the Members shall be held without notice, other than these By-Laws, immediately after and at the same place as the annual meeting of the Members of the Corporation. Such meeting shall be the annual meeting of the Members at which Officers of the Corporation shall be elected. Other regular monthly meetings of the Members shall be held at such time and place as determined by the Members.

Section 2

- Special meetings of the Members shall be called by the President or upon written request of one-third (1/3) of the Members then serving. The person or persons authorized to call special meetings may fix the time and place for these meetings. The written notice requirement may be waived in writing by any Members before or after the meeting.

Section 3

- The action of the majority of the Members attending a meeting shall be the action of the Members consistent with the Articles of Incorporation, By-Laws or law.

Article V

Officers

Section 1

- The Officers of the Corporation shall be the President, Vice President, Secretary and Treasurer.

Section 2

- The Officers shall be elected by and from the Members at its annual meeting. If the election of Officers is not held at the annual meeting, the election shall take place as soon as it conveniently may be done. Each Officer shall hold office until the next annual meeting of the Corporation or until a successor has been duly elected. Nominations and elections of Officers may be done by secret ballot, if the Members so determine.

Section 3

- Any Officers elected by the Members may be removed by a majority vote of all the Members then serving, whenever in their judgment the best interest of the Corporation would be served. Members up for removal will be advised as to the Members' concern(s) prior to the meeting in which their continued Membership will be voted on and will be permitted to attend and defend their position. Any Member that is removed must turn over all materials used in regard to their Membership with the Corporation to an Officer.

Section 4

- Except as otherwise provided in these By-Laws, a vacancy in any office may be filled by the Members for the unfinished portion of the term.

Section 5

- The President shall be the principal executive Officer of the Corporation and shall:
 - Preside at all meetings of the Corporation and the Members.
 - Sign all contracts and other instruments authorized by the Members unless execution thereof has been expressly delegated by the Members or these By-Laws to another Officer of the Corporation.
 - Approve all materials containing Corporation logo, name and/or events.
 - Perform all duties of the office of the President as prescribed by the Members.
 - Assign responsibilities to other Officers and Members.
 - Only vote in the event of a tie.
 - Set the agenda for regular monthly meetings.

Section 6

- The Vice President shall perform the duties of the President in the absence, inability or refusal to act of the President and shall perform such other duties as assigned by the President or the Members.

Section 7

- The Secretary shall keep minutes of the meetings of the Corporation and shall keep on file a complete, current copy of the Articles of Incorporation and By-Laws of the Corporation. The Secretary shall be responsible for maintaining Memberships in The Corporation and will issue such Membership nametags, as authorized by the Members. The Members may designate a person to serve as an assistant to the Secretary to perform the duties of the office in the absence or disability of the Secretary.

Section 8

- The Treasurer shall function as the financial officer of the Corporation, shall be the custodian of all the records of the Corporation and shall complete all annual tax forms and shall perform other duties as assigned by the Members, unless these items are already being completed by the Bookkeeper. Officers may designate a person to serve as an assistant to the Treasurer to perform the duties of the office in the absence or disability of the Treasurer.

Article VI

Committees

Section 1

- The Members shall establish such standing and special Committees, as it deems necessary, and shall provide for the method of selection, qualifications and tenure of the Members of each Committee. Each Committee will be lead by a Committee Chair. Committee Chairs are to be elected for one (1) year terms in the position.

Article VII

Contracts, Checks and Deposits

Section 1

- Officers shall designate a financial institution for all funds to be deposited to the credit of the Corporation.

Article VIII

Conduct of Meeting

Section 1

- All meetings of the Members and the Corporation may be governed by the most recent edition of "Robert's Rules of Order," except as otherwise required by the Articles of Incorporation, By-Laws or by the resolution of the Members.

Article IX

Avoidance of Conflict of Interest

Section 1

- No Officer, Member or Volunteer shall use their position in a manner that a conflict between their personal interest and the interest of the Corporation arises, or the person or dependent relative obtains improper personal gain or advantage.

Section 2

- All Officers, Members and Volunteers shall disclose any activities which may be considered a conflict of interest in accordance with the Articles of Incorporation. These disclosures shall be reviewed by a committee appointed by the President or the Members. The Corporation will determine if a conflict of interest exists and shall attempt to resolve any such conflict with the person involved. In the event no resolution is possible, the matter shall be referred to the Members to take action as appropriate.

Section 3

- When an Officer, Member or Volunteer fails to report a potential conflict of interest, as required by this article, or fails to resolve the prohibited conflict of interest, such Officer, Member or Volunteer shall be subject to suspension or removal from office by the Members.

Article X

Fiscal Year

Section 1

- The fiscal year of the Corporation shall begin on the first day of January each year and end on the last day of December of the same year (amended August 19, 2010).

Article XI

Section 1

- Amendments to these By-Laws may be proposed by the Officers of the Corporation at their discretion. Adoption of amendments shall require majority vote by the Members.

Definitions

1. **Corporation:** Refers to the Richfield 4th of July Committee, Inc.
2. **Membership:** Includes, but is not limited to: Officers, Members and Volunteers.
3. **Officer:** Members who have been elected to hold one (1) of four (4) positions: President, Vice President, Treasurer or Secretary.
4. **Member:** Person who has completed a Membership Application and meets the requirements of Article I. Members are eligible to vote at and are expected to attend regular Committee meetings. Members will be awarded a one (1) year term initially and then continued Membership indefinitely after that period. Elected Members shall act as the Committee of the Corporation.
5. **Volunteer:** Person who assists at or with a specific event or task. Volunteers are not required to attend Committee meetings.
6. **Committee Roster:** A document containing contact information for Officers, Members and Volunteers of the Corporation.
7. **Committee Structure:** A document containing the organizational chart of the Corporation.
8. **Committee Chair:** Person who has been elected by the Committee to organize and supervise the Coordinators that are in their subcommittee structure.
9. **Coordinator:** Person who has been designated by the Committee Chair to assist in a particular event.
10. **Liaison:** Person who represents the City of Richfield, Public Safety Department and/or a business employee. Liaisons are not voting members, but may request time slots on the agenda and are invited to attend all Committee meetings. Liaisons will hold a Volunteer status on the Committee.

(Revised 04/08/2014)



Report Prepared By:

Jake Whipple, Civil Engineer

Department Director:

Kristin Asher, Public Works Director

Item for Consideration:

Consider a resolution authorizing the Mayor and City Manager to finalize and execute a Cooperative Construction Agreement with the State of Minnesota Department of Transportation, Contract No. 1061135, for the 73rd Street Trail project completed in 2025.

EXECUTIVE SUMMARY

The 73rd Street Trail project was completed in 2025 near Centennial Elementary School. The project's limits went into the State of Minnesota Department of Transportation (MnDOT) right-of-way. This Cooperative Construction Agreement covers maintenance responsibilities between MnDOT and the City of Richfield at or near the intersection of 73rd Street and Cedar Avenue.

City staff, the City Attorney and MnDOT staff have agreed upon the terms of this Cooperative Construction Agreement.

RECOMMENDED ACTION

By Motion: Approve the resolution authorizing the Mayor and City Manager to finalize and execute a Cooperative Construction Agreement with the State of Minnesota Department of Transportation, Contract No. 1061135, for the 73rd Street Trail project completed in 2025.

HISTORICAL CONTEXT

In 2022, Richfield applied for and was awarded a federal grant through the Metropolitan Council's Regional Solicitation for construction of a trail on 73rd Street between Bloomington Ave and Cedar Ave adjacent to Centennial Elementary School. The award was for fiscal year 2026 (since accelerated to 2025). The project scope included a shared use path on one side of the road, with an associated curb relocation to narrow the roadway to 28 feet from curb to curb.

In early 2023, Richfield and MnDOT executed a Delegated Contract Process (DCP) Agency agreement. This agreement is a standard agreement between the agencies to allow MnDOT to accept and distribute federal funds on behalf of a local agency. This has been a standard practice in Minnesota for decades, simplifying the process for local agencies and ensuring that the local agencies are able to meet the requirements set forth in federal law.

In 2023, the Centennial Elementary location was the recipient of an Active

Transportation grant for a demonstration project through MnDOT. This demonstration project was in place from August 2023 until construction of the permanent improvements in summer 2025.

Through 2024 and early 2025, the project design was completed with participation from the public, Richfield Public Schools, and the Transportation Commission. Open Houses were held at Centennial Elementary school in the fall of 2024. This process led to several changes to the proposed grant scope. The trail was moved from the north side of 73rd to the south side of 73rd for better connectivity with the school, curb extensions were added to shorten crossing distances and provide sight lines at several intersections, and raised crosswalks were added at 3 locations.

This project construction was completed in Fall 2025.

EQUITABLE OR STRATEGIC CONSIDERATIONS OR IMPACTS

Strategic Consideration: The proposed Cooperative Construction Agreement clarifies the responsibility of maintenance for infrastructure constructed during the 73rd Street Trail (Safe Routes to School) project in MnDOT right-of-way.

POLICIES (RESOLUTIONS, ORDINANCES, REGULATIONS, STATUTES, ETC.)

- The Cooperative Construction Agreement aligns with City standard maintenance policies and practices.

CRITICAL TIMING ISSUES

A Cooperative Construction Agreement with MnDOT on MnDOT right-of-way is standard business. MnDOT staff have indicated that they would like a signed agreement and resolution as soon as feasible.

FINANCIAL IMPACT

- Execution of this agreement has no direct costs.
- The City will incur routine maintenance expenses and possible future replacement costs in order to maintain the City-owned path/trail and roadway crossings that fall on MnDOT property. These costs are no different than they would have been had the project been built entirely on City right-of-way.

LEGAL CONSIDERATIONS

The City Attorney has reviewed the agreement and will be available for any questions.

ALTERNATIVE RECOMMENDATION(S)

N/A

ATTACHMENTS

1. Resolution 2026-XXXXX 73rd Cooperative Agreement
2. Exhibit A - Project extents at MnDOT ROW
3. 73rd Street SRTS Trail Cooperative Agreement - 4.20.2026

RESOLUTION NO. XXXXX

Motion by:
Seconded by:

**A RESOLUTION AUTHORIZING EXECUTION OF COOPERATIVE AGREEMENT
WITH THE STATE OF MINNESOTA DEPARTMENT OF TRANSPORTATION,
FOR THE 73RD STREET TRAIL PROJECT, CONTRACT NO. 1061135**

WHEREAS, that the City of Richfield enter into MnDOT Agreement No. 1061135 with the State of Minnesota, Department of Transportation for the following purposes:

1. To provide for routine maintenance by the City upon, along, and adjacent to Trunk Highway No. 77, the limits of which are defined in said Agreement.

IT IS FURTHER RESOLVED, that the Mayor and the City Manager are authorized to execute the Agreement and any amendments to the Agreement.

Adopted by the City Council of the City of Richfield, Minnesota this 12th day of May, 2026.

VOTING AYE

- Supple, Mary**
- Burk, Walter**
- Christensen, Sharon**
- Coleman-Woods, Rori**
- Hayford Oleary, Sean**

VOTING NAY

- Supple, Mary**
- Burk, Walter**
- Christensen, Sharon**
- Coleman-Woods, Rori**
- Hayford Oleary, Sean**

Mary B. Supple, Mayor

ATTEST:

Michelle Friedrich, City Clerk

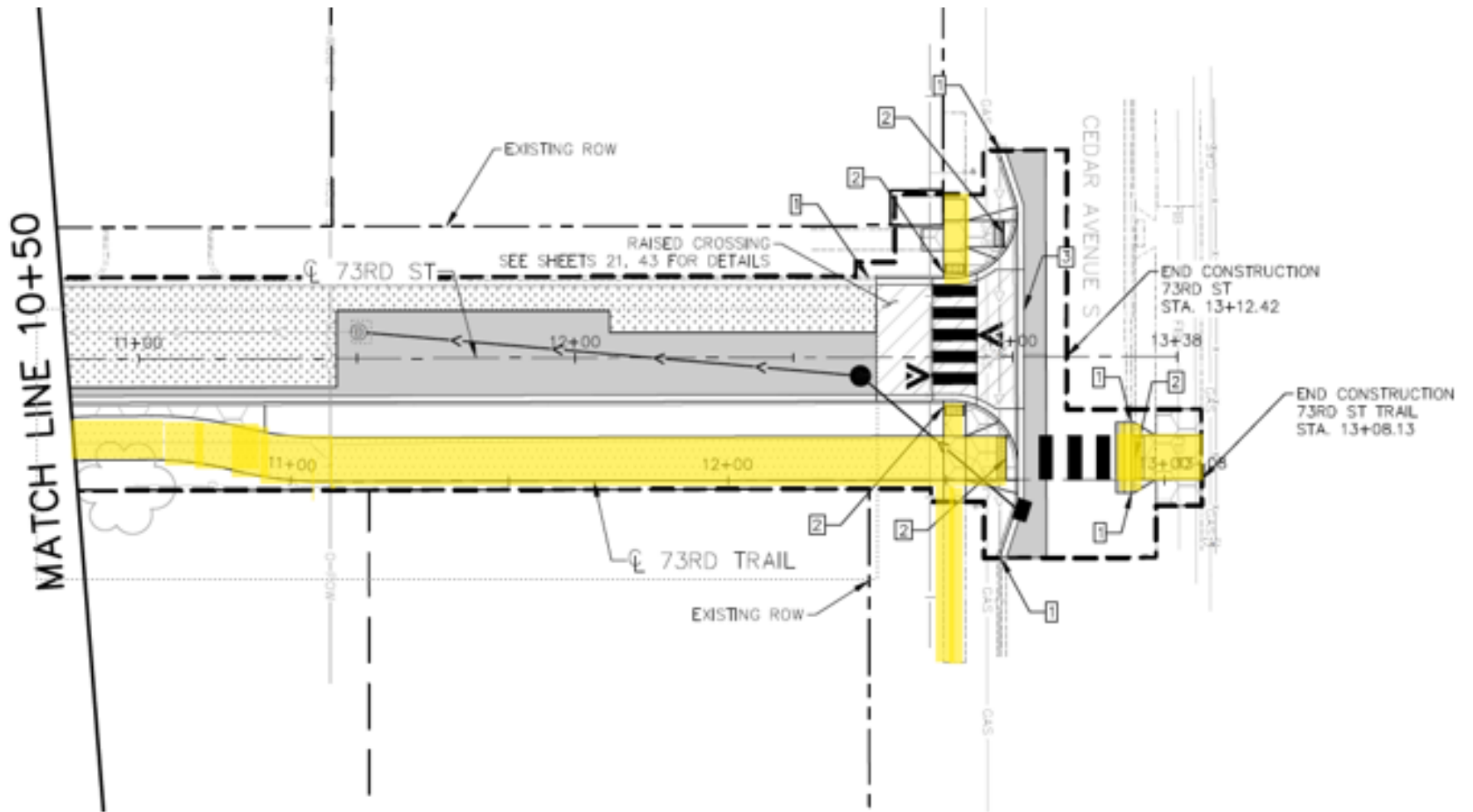

Maintenance by City

**STATE OF MINNESOTA
DEPARTMENT OF TRANSPORTATION
And
CITY OF RICHFIELD
COOPERATIVE CONSTRUCTION
AGREEMENT**

State Project Number (S.P.): 157-591-003
Trunk Highway Number (T.H.): 77
Federal Project Number: TA 2725(240)
City Project Number: 41083

This Agreement is between the State of Minnesota, acting through its Commissioner of Transportation ("State") and the City of Richfield acting through its City Council ("City").

Recitals

1. The City will perform grading, bituminous surfacing, concrete raised crossing, mill and overlay, shared use path and ADA improvements construction, and other associated construction upon, along, and adjacent to Trunk Highway No. 77 from 73rd Street East from Bloomington Avenue South to Cedar Avenue South according to City prepared plans, specifications, and special provisions designated by the City as State Project No. 157-591-003; and
2. The City requests the State allow the construction of a portion of the Shared-Use Path (SUP) and sidewalk on State Right-of-Way at the intersection of TH 77 and 73rd Street East in the City of Richfield and the State is willing to allow said construction; and
3. Minnesota Statutes § 161.20, subdivision 2 authorizes the Commissioner of Transportation to make arrangements with and cooperate with any governmental authority for the purposes of constructing, maintaining, and improving the trunk highway system.

Agreement

1. Term of Agreement; Survival of Terms; Plans; Incorporation of Exhibits

- 1.1. *Effective Date.*** This Agreement will be effective on the date the State obtains all signatures required by Minnesota Statutes § 16C.05, subdivision 2.
- 1.2. *Expiration Date.*** This Agreement will expire when all obligations have been satisfactorily fulfilled.
- 1.3. *Survival of Terms.*** All clauses which impose obligations continuing in their nature and which must survive in order to give effect to their meaning will survive the expiration or termination of this Agreement, including, without limitation, the following clauses: 2.4. State Ownership of Improvements; 5. Maintenance by the City; 8. Liability; Worker Compensation Claims; Insurance; 10. State Audits; 11. Government Data Practices; 13. Governing Law; Jurisdiction; Venue; and 15. Force Majeure.
- 1.4. *Plans, Specifications, and Special Provisions.*** State-approved City plans, specifications, and special provisions designated by the City as State Project No. 157-591-003 (T.H. 77) are on file in the office of the City's Engineer and incorporated into this Agreement by reference ("Project Plans").
- 1.5. *Exhibits.*** Exhibit A: Intersection of 73rd St. and TH 77/Cedar Avenue S.

2. Right-of-Way Use

- 2.1. Limited Right to Occupy.** The State grants to the City (and its contractors and consultants) the right to occupy Trunk Highway Right-of-Way as necessary to perform the work described in the Project Plans. This right is limited to the purpose of constructing the project, and administering such construction, and may be revoked by the State at any time, with or without cause. Cause for revoking this right of occupancy includes, but is not limited to, breaching the terms of this or any other agreement (relevant to this project) with the State, failing to provide adequate traffic control or other safety measures, failing to perform the construction properly and in a timely manner, and failing to observe applicable environmental laws or terms of applicable permits. The State will have no liability to the City (or its contractors or consultants) for revoking this right of occupancy.
- 2.2. State Access; Suspension of Work; Remedial Measures.** The State's District Engineer or assigned representative retains the right to enter and inspect the Trunk Highway Right-of-Way (including the construction being performed on such right-of-way) at any time and without notice to the City or its contractor. If the State determines (in its sole discretion) that the construction is not being performed in a proper or timely manner, or that environmental laws (or the terms of permits) are not being complied with, or that traffic control or other necessary safety measures are not being properly implemented, then the State may notify and require the City (and its contractors and consultants) to suspend their operations until the City (and its contractors and consultants) take all necessary actions to rectify the situation to the satisfaction of the State. The State will have no liability to the City (or its contractors or consultants) for exercising or failing to exercise its rights under this provision.
- 2.3. Traffic Control; Worker Safety.** While the City (and its contractors and consultants) are occupying the State's Trunk Highway Right-of-Way, they must comply with the approved traffic control plan, and with applicable provisions of the Work Zone Field Handbook (<http://www.dot.state.mn.us/trafficeng/workzone/index.html>). All City, contractor, and consultant personnel occupying the State's Trunk Highway Right-of-Way must be provided with required reflective clothing and hats.
- 2.4. State Ownership of Improvements.** The State will retain ownership of its Trunk Highway Right-of-Way, including any improvements made to such right-of-way under this Agreement, unless otherwise noted. The warranties and guarantees made by the City's contractor with respect to such improvements (if any) will flow to the State. The City will assist the State, as necessary, to enforce such warranties and guarantees, and to obtain recovery from the City's consultants, and contractor (including its sureties) for non-performance of contract work, for design errors and omissions, and for defects in materials and workmanship. Upon request of the State, the City will undertake such actions as are reasonably necessary to transfer or assign contract rights to the State and to permit subrogation by the State with respect to claims against the City's consultants and contractors.

3. Contract Award and Construction

- 3.1. Direction, Supervision, and Inspection of Construction.**
- A. The contract construction will be under the direction of the City and under the supervision of a registered professional engineer; however, the State participation construction covered under this Agreement will be open to inspection by the State District Engineer's authorized representatives. The City will give the State Aid Agreements Engineer at Waters Edge five days notice of its intention to start the contract construction.

B. Responsibility for the control of materials for the contract construction will be on the City and its contractor and will be carried out according to Specifications No. 1601 through and including No. 1609 in the State's current "Standard Specifications for Construction".

3.2. Completion of Construction. The City will cause the contract construction to be started and completed according to the time schedule in the construction contract special provisions. The completion date for the contract construction may be extended, by an exchange of letters between the appropriate City official and the State District Engineer's authorized representative, for unavoidable delays encountered in the performance of the contract construction.

3.3. Compliance with Laws, Ordinances, and Regulations. The City will comply and cause its contractor to comply with all Federal, State, and Local laws, and all applicable ordinances and regulations. With respect only to that portion of work performed on the State's Trunk Highway Right-of-Way, the City will not require the contractor to follow local ordinances or to obtain local permits.

4. Right-of-Way; Easements; Permits

4.1. The City will, without cost or expense to the State, obtain all rights-of-way, easements, construction permits, and any other permits and sanctions that may be required in connection with the local and trunk highway portions of the contract construction.

4.2. The City will comply with Minnesota Statutes § 216D.04, subdivision 1(a), for identification, notification, design meetings, and depiction of utilities affected by the contract construction.

5. Maintenance by the City

Upon completion of the project, the City will provide the following without cost or expense to the State:

5.1. Sidewalks. Maintenance of any sidewalk construction, including stamped and colored concrete sidewalk (if any) and pedestrian ramps. Maintenance includes, but is not limited to, winter maintenance according to City standard practices, debris removal, patching, crack repair, panel replacement, cross street pedestrian crosswalk markings, vegetation control of boulevards (if any), and any other maintenance activities necessary to perpetuate the sidewalks in a safe, useable, and aesthetically acceptable condition.

5.2. Shared Use Path. Maintenance of the Shared Use Path on Trunk Highway No. 77 Right-of-Way. At the intersection with 73rd Street East. Maintenance includes, but is not limited to, winter maintenance according to City standard practices, snow control/removal, sweeping and debris removal, patching, crack repair, pavement replacement, vegetation control, signing, pavement markings, and any other maintenance activities necessary to perpetuate the Shared Use Path in a safe, usable, and aesthetically acceptable condition as determined by the State. The City will maintain the Shared Use Path in compliance with all applicable laws, rules, ordinances and regulations issued by any federal, state or local political subdivision having jurisdiction and authority in connection with the Shared Use Path, including the Americans with Disabilities Act ("ADA"). In the event that there is conflict or ambiguity between federal or state law and local ordinances, federal or state law will have precedent over the local ordinances. If the Shared Use Path is not maintained in compliance with the ADA or other applicable laws, the State will notify the City for corrective work. If the Shared Use Path is not maintained in compliance with the ADA or other applicable laws, the State may perform such obligation and the City shall reimburse the State for the cost thereof, plus 10% of such cost for overhead and supervision within 30 days of receipt of the State's invoice.

5.3. Environmental. The City shall not dispose of any materials regulated by any governmental or regulatory agency onto the ground, or into any body of water, or into any container on the State's Right-of-Way. In the event of spillage of regulated materials, the City shall immediately notify the State's Authorized

Representative in writing and shall provide for cleanup of the spilled material and any materials contaminated by the spillage in accordance with all applicable federal, state and local laws and regulations, at the sole expense of the City.

5.4. Additional Drainage. No party to this Agreement will drain any additional drainage volume into the storm sewer facilities constructed under the construction contract that was not included in the drainage for which the storm sewer facilities were designed, without first obtaining written permission to do so from the other party.

6. Authorized Representatives

Each party's Authorized Representative is responsible for administering this Agreement and is authorized to give and receive any notice or demand required or permitted by this Agreement.

6.1. The State's Authorized Representative will be:

Name, Title: Todd Stevens, District Maintenance Engineer (or successor)
Address: 1500 West County Road B2, Roseville MN 55113
Telephone: 651-234-7901
E-Mail: todd.stevens@state.mn.us

6.2. The City's Authorized Representative will be:

Name, Title: Joe Powers, City Engineer (or successor)
Address: 6700 Portland Avenue, Richfield, MN 55423
Telephone: 612-861-9791
E-Mail: jpowers@richfieldmn.gov

7. Assignment; Amendments; Waiver; Contract Complete

7.1. Assignment. No party may assign or transfer any rights or obligations under this Agreement without the prior consent of the other party and a written assignment agreement, executed and approved by the same parties who executed and approved this Agreement, or their successors in office. The foregoing does not prohibit the City from contracting with a third party to perform City maintenance responsibilities covered under this Agreement.

7.2. Amendments. Any amendment to this Agreement must be in writing and will not be effective until it has been executed and approved by the same parties who executed and approved the original Agreement, or their successors in office.

7.3. Waiver. If a party fails to enforce any provision of this Agreement, that failure does not waive the provision or the party's right to subsequently enforce it.

7.4. Contract Complete. This Agreement contains all prior negotiations and agreements between the State and the City. No other understanding regarding this Agreement, whether written or oral, may be used to bind either party.

8. Liability; Worker Compensation Claims; Insurance

8.1. Each party is responsible for its own acts, omissions, and the results thereof to the extent authorized by law and will not be responsible for the acts, omissions of others, and the results thereof. Minnesota Statutes § 3.736 and other applicable law govern liability of the State. Minnesota Statutes Chapter 466 and other applicable law govern liability of the City. Notwithstanding the foregoing, the City will indemnify, hold harmless, and defend (to the extent permitted by the Minnesota Attorney General) the State against any claims, causes of actions, damages, costs (including reasonable attorneys fees), and expenses arising in

connection with the project covered by this Agreement, regardless of whether such claims are asserted by the City's contractor(s) or consultant(s) or by a third party because of an act or omission by the City or its contractor(s) or consultant(s).

8.2. Each party is responsible for its own employees for any claims arising under the Workers Compensation Act.

8.3. The City may require its contractor to carry insurance to cover claims for damages asserted against the City's contractor.

9. Nondiscrimination

Provisions of Minnesota Statutes § 181.59 and of any applicable law relating to civil rights and discrimination are considered part of this Agreement.

10. State Audits

Under Minnesota Statutes § 16C.05, subdivision 5, the City's books, records, documents, accounting procedures, and practices relevant to this Agreement are subject to examination by the State and the State Auditor or Legislative Auditor, as appropriate, for a minimum of six years from the end of this Agreement.

11. Government Data Practices

The City and State must comply with the Minnesota Government Data Practices Act, Minnesota Statutes Chapter 13, as it applies to all data provided under this Agreement, and as it applies to all data created, collected, received, stored, used, maintained, or disseminated by the City under this Agreement. The civil remedies of Minnesota Statutes §13.08 apply to the release of the data referred to in this clause by either the City or the State.

12. Telecommunications Certification.

By signing this agreement, the City certifies that, consistent with Section 889 of the John S. McCain National Defense Authorization Act for Fiscal Year 2019, Pub. L. 115-232 (Aug. 13, 2018), and 2 CFR 200.216, the City will not use funding covered by this agreement to procure or obtain, or to extend, renew, or enter into any contract to procure or obtain, any equipment, system, or service that uses "covered telecommunications equipment or services" (as that term is defined in Section 889 of the Act) as a substantial or essential component of any system or as critical technology as part of any system. The City will include this certification as a flow down clause in any contract related to this agreement.

13. Governing Law; Jurisdiction; Venue

Minnesota law governs the validity, interpretation, and enforcement of this Agreement. Venue for all legal proceedings arising out of this Agreement, or its breach, must be in the appropriate state or federal court with competent jurisdiction in Ramsey County, Minnesota.

14. Termination; Suspension

14.1. By Mutual Agreement. This Agreement may be terminated by mutual agreement of the parties or by the State for insufficient funding as described below.

15. Force Majeure

No party will be responsible to the other for a failure to perform under this Agreement (or a delay in performance), if such failure or delay is due to a force majeure event. A force majeure event is an event beyond a party's reasonable control, including but not limited to, unusually severe weather, fire, floods, other acts of God, labor disputes, acts of war or terrorism, or public health emergencies.

[The remainder of this page has been intentionally left blank]

DEPARTMENT OF TRANSPORTATION

Recommended for Approval:

By: _____
(District Engineer)

Date: _____

Approved:

By: _____
(State Design Engineer)

Date: _____

COMMISSIONER OF ADMINISTRATION

By: _____
(With Delegated Authority)

Date: _____

CITY OF RICHFIELD

The undersigned certify that they have lawfully executed this contract on behalf of the Governmental Unit as required by applicable charter provisions, resolutions, or ordinances.

By: _____

Title: Mayor

Date: _____

By: _____

Title: City Manager

Date: _____

INCLUDE COPY OF RESOLUTION APPROVING THE AGREEMENT AND AUTHORIZING ITS EXECUTION.

CITY OF RICHFIELD

RESOLUTION

IT IS RESOLVED that the City of Richfield enter into MnDOT Agreement No. 1061135 with the State of Minnesota, Department of Transportation for the following purposes:

To provide for routine maintenance by the City upon, along, and adjacent to Trunk Highway No. 77, the limits of which are defined in said Agreement.

IT IS FURTHER RESOLVED that the Mayor and the _____ **City Manager** _____
(Title)
are authorized to execute the Agreement and any amendments to the Agreement.

CERTIFICATION

I certify that the above Resolution is an accurate copy of the Resolution adopted by the Council of the City of Richfield at an authorized meeting held on the _____ **12th** _____ day of _____ **May** _____, 2026, as shown by the minutes of the meeting in my possession.

Subscribed and sworn to me this _____ day of _____, 2026
Notary Public _____
My Commission Expires _____

(Signature)

(Type or Print Name)

(Title)

Exhibit A

Intersection of 73rd St.

and

TH 77/Cedar Avenue S.

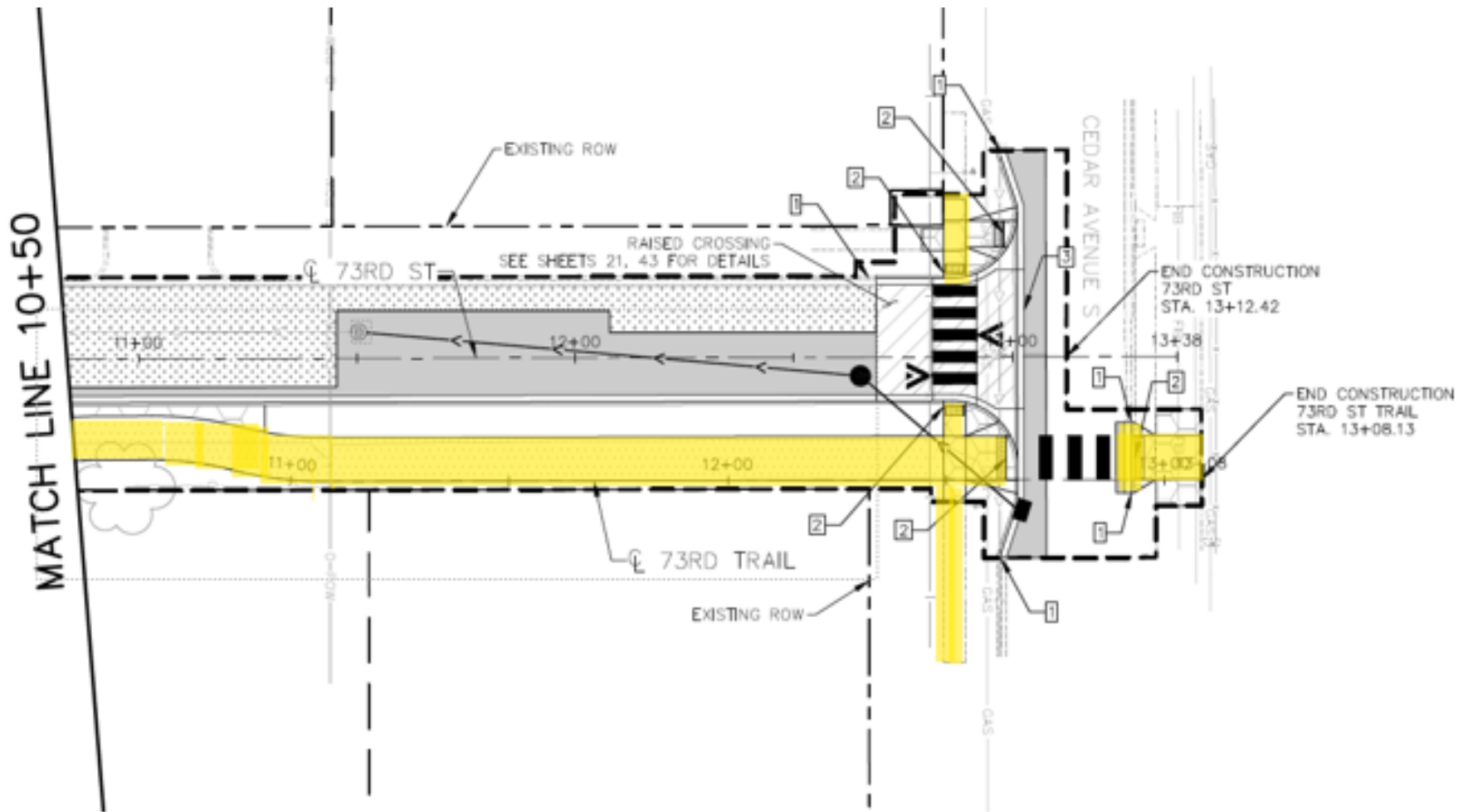

Maintenance by City



Report Prepared By:

Jennifer Anderson, Support Services Manager

Department Director:

Jay Henthorne, Police Chief

Item for Consideration:

Consider approval of a request for a new Secondhand Goods Dealer license for EcoAtm, LLC, located at 6540 Penn Avenue South (located in CVS).

EXECUTIVE SUMMARY

On March 27, 2026, the City received an application for a new Secondhand Goods Dealer license for EcoAtm, LLC, located at 6540 Penn Avenue South (inside the CVS). All required information, documents and fees have been received.

The Public Safety background investigation has been completed. The Public Safety Director has reviewed the background investigation report. None of the information in the report would cause the Public Safety Director to recommend denial of the requested license.

RECOMMENDED ACTION

By Motion: Approve the request for a new Secondhand Goods Dealer license for EcoAtm, LLC, located at 6540 Penn Avenue South (inside the CVS).

HISTORICAL CONTEXT

The Public Safety background investigation has been completed and reveals the following:

- The applicant has paid the required licensing fees.
- The required license and permit bond for \$1,500.00 was issued by RLI Insurance Company.
- All real estate and personal property taxes due and payable for the premises have been paid.
- A criminal background check was conducted on the applicant and no criminal history was found.

EQUITABLE OR STRATEGIC CONSIDERATIONS OR IMPACTS

The Richfield Police Department is committed to ensuring equity and inclusivity in our work. In some instances, equity considerations may not directly apply; however, DEI principles are always considered.

POLICIES (RESOLUTIONS, ORDINANCES, REGULATIONS, STATUTES, ETC.)

The applicant has complied with all the provisions of the application process.

CRITICAL TIMING ISSUES

There are no critical timing issues.

FINANCIAL IMPACT

Licensing fees have been received.

LEGAL CONSIDERATIONS

There are no legal considerations.

ALTERNATIVE RECOMMENDATION(S)

Deny the request for the Secondhand Goods Dealer license for EcoAtm, LLC; however, Public Safety has not found any basis for denial.

ATTACHMENTS

None



Report Prepared By:

Mattias Oddsson, Water Resources Engineer

Department Director:

Kristin Asher, Public Works Director

Item for Consideration:

Consider a resolution authorizing the Mayor and City Manager to enter into an agreement with the Conservation Corps of Minnesota for installation of rain gardens funded by the Richfield-Bloomington Watershed Management Organization (RBWMO) Grant Program.

EXECUTIVE SUMMARY

The RBWMO is currently piloting a residential grant program to provide technical, installation, and cost share assistance to residents to install rain gardens on their property. This program is financed through a combination of state Watershed-Based Implementation Grant funds and local storm utility funds, while installation is planned to be completed by staff from the Conservation Corps of Minnesota and Iowa (CCMI). The City must enter into an agreement with CCMI to proceed with planned construction of rain gardens for this program.

RECOMMENDED ACTION

By Motion: Approve the resolution authorizing the Mayor and City Manager to enter into an agreement with the Conservation Corps of Minnesota for installation of rain gardens funded by the RBWMO Grant Program.

HISTORICAL CONTEXT

In 2024, the City Councils of Richfield and Bloomington, acting in their capacity as the RBWMO Board, provided direction to staff to develop a grant program for residents in the RBWMO area.

The board of the RBWMO voted to approve a proposed minor plan amendment at the March 11, 2025 annual meeting to incorporate a Grant Program into the Implementation Program (Section 5) of the RBWMO's Comprehensive Watershed Management Plan.

The grant program is now being implemented, and the first batch of residential rain gardens is planned for installation starting in mid-May.

EQUITABLE OR STRATEGIC CONSIDERATIONS OR IMPACTS

This initiative advances the City's strategic priority of sustainable infrastructure.

POLICIES (RESOLUTIONS, ORDINANCES, REGULATIONS, STATUTES, ETC.)

This program was adopted into the RBWMO Comprehensive Watershed Management Plan through a minor plan amendment in 2025.

CRITICAL TIMING ISSUES

Prompt approval of this agreement will ensure that installation of rain gardens can proceed in a timely manner and align with ideal times for planting.

FINANCIAL IMPACT

- CCMI crews are funded through the Clean Water Fund, with no direct monetary cost to the City incurred.
- The RBWMO grant program is funded by Watershed-Based Implementation funding from the Board of Water and Soil Resources and local match funds from each City stormwater utility:
 - \$750 from the City of Richfield; and
 - \$750 from the City of Bloomington.

LEGAL CONSIDERATIONS

The City Attorney has reviewed the agreement and will be available to answer any questions.

ALTERNATIVE RECOMMENDATION(S)

None.

ATTACHMENTS

1. 2026-05-12 Resolution 2026-XXXXX RBWMO Rain Garden Program Richfield CCMI Agreement
2. 11293_220_City_of_Richfield__RBWMO_Rain_Garden_Program

RESOLUTION NO. XXXXX

Motion by:

Seconded by:

**A RESOLUTION AUTHORIZING EXECUTION OF A WORK ORDER AGREEMENT
WITH THE CONSERVATION CORPS MINNESOTA & IOWA
FOR THE CITY OF RICHFIELD & RBWMO RAIN GARDEN PROGRAM, PROJECT NO. 220-11293**

WHEREAS, the City of Richfield is a member city of the Richfield-Bloomington Watershed Management Organization (RBWMO); and

WHEREAS, the RBWMO has developed and implemented a program to assist residents with the construction of rain gardens; and

WHEREAS, the installation of rain gardens through the RBWMO program is to be performed by the Conservation Corps Minnesota & Iowa (CCMI); and

WHEREAS, the City of Richfield must enter into a work order agreement with the CCMI prior to the commencement of work.

NOW, THEREFORE, BE IT RESOLVED BY THE CITY COUNCIL OF THE CITY OF RICHFIELD, MINNESOTA that the Mayor and City Manager are hereby authorized to execute the work order agreement with the CCMI for the RBWMO Rain Garden Program.

Adopted by the City Council of the City of Richfield, Minnesota this 12th day of May, 2026.

VOTING AYE

- Supple, Mary**
- Burk, Walter**
- Christensen, Sharon**
- Coleman-Woods, Rori**
- Hayford Oleary, Sean**

VOTING NAY

- Supple, Mary**
- Burk, Walter**
- Christensen, Sharon**
- Coleman-Woods, Rori**
- Hayford Oleary, Sean**

Mary B. Supple, Mayor

ATTEST:

Michelle Friedrich, City Clerk

CLEAN WATER GRANT FUND WORK ORDER BETWEEN
City of Richfield
AND CONSERVATION CORPS MINNESOTA & IOWA
Project Number: 220-11293

This work order is between City of Richfield (hereafter referred to as "PROJECT HOST") and CONSERVATION CORPS MINNESOTA & IOWA, 60 Plato Blvd R #210, St. Paul, MN 55107 (hereafter referred to as "THE CORPS"). This work order is issued under the authority of Minnesota Statute § 15.061, 103B.101 and ML 2025, Chapter 36, Article 2, Section 6(p), which requires the Board to contract with the Conservation Corps for restoration, maintenance, and other activities.

TERM OF WORK ORDER

- 1.1 **Effective date:** 05/04/2026, or the date THE CORPS obtains all required signatures under, whichever is later.
- 1.2 **Expiration date:** 11/30/2026, or until all obligations have been satisfactorily fulfilled, whichever occurs first.

DUTIES OF THE CORPS

- 2.1 Perform services as specified in Clean Water Fund Project Request Form, which is attached hereto, and shall be a part of this work order (the "Project").
- 2.2 Enroll and supervise members ("corpsmembers") in accordance with program guidelines.
- 2.3 Provide basic orientation and training as appropriate for corpsmembers.
- 2.4 Provide consultation and on-site project review to ensure the Project is progressing in accordance with this work order and program guidelines.
- 2.5 Provide personnel and payroll administration for corpsmembers.
- 2.6 Provide all necessary transportation of corpsmembers to and from service sites.
- 2.7 Provide basic tools, safety gear, personal supplies and equipment needed by corpsmembers to meet all PROJECT HOST and federal safety requirements. Provide professional liability and worker's compensation insurance for all corpsmembers in such amount as is considered commercially reasonable by THE CORPS.
- 2.8 Track services completed and make this information available to PROJECT HOST upon request.
- 2.9 Report financial information on the use of state funds, and outcome and match information in eLINK using information provided by the PROJECT HOST.
- 2.10 Except as expressly provided herein, services are provided "AS-IS" and with all faults THE CORPS makes no warranty, either express or implied, concerning the services.

DUTIES OF PROJECT HOST

- 3.1 Provide Project specific direction and assistance to the corpsmember(s).
- 3.2 Comply with grant program requirements for the FY26 Clean Water Fund Legacy Partners Grant Program (available on the BWSR website - <https://bwsr.state.mn.us/node/10511>)
- 3.3 Provide at least one media promotion to the public stating that the services(s) are being performed by THE CORPS. Any publicity regarding the subject matter of this work order must not be released without prior approval from THE CORPS' Authorized Representative.
- 3.4 Ensure safe working conditions in and around Project areas that meet all state and federal standards.
- 3.5 Secure all local, county, and federal permits required by law prior to the commencement of services.
- 3.6 Provide corpsmembers with training and educational opportunities relevant to the services being performed. This includes an on-site Project overview at the outset of the Project which outlines Project background, goals and overall outcomes expected as a result of the corpsmembers' efforts.
- 3.7 Provide specialized tools, safety gear, personal supplies and equipment that are not available through the Corps that is needed by corpsmembers to meet all state and federal safety requirements.
- 3.8 Assist in the acquisition of camping/lodging accommodations if necessary.
- 3.9 Provide all Project materials, supplies and chemicals.

PAYMENT

- 4.1 THE CORPS will pay for services performed, utilizing its Clean Water Grant Fund accounts. Expenditures from these accounts shall be expended only for the purposes for which they were approved and intended.
- 4.2 Materials (chemicals, lumber, hardware, plant material, etc.) shall be provided by the PROJECT HOST at the expense of the PROJECT HOST.

CANCELLATION

- 5.1 This work order may be terminated by the PROJECT HOST or THE CORPS at any time, with or without cause, upon 30 days written notice to the other party. In the event of such cancellation, THE CORPS shall expend dedicated funds for services performed up to date of cancellation.
- 5.2 THE CORPS reserves the right to withdraw corpsmembers from PROJECT HOST for emergency response work including, but not limited to, natural disasters and wild fire response. THE CORPS will make reasonable efforts to accommodate the needs of the PROJECT HOST to ensure rescheduling.
- 5.3 THE CORPS reserves the right to alter project schedules, duties or lodging to accommodate environmental hazards that pose a safety concern for members such as extreme heat or elevated air quality index based on written Corps policy and state and federal guidance. In these events, THE CORPS will make reasonable efforts to accommodate the needs of the PURCHASER and work collaboratively to cover any additional costs related to lodging changes and project delays.

AUTHORIZED REPRESENTATIVES

- 6.1 The PROJECT HOST's Authorized Representative is Mattias Oddsson, Water Resources Engineer, or their successor
- 6.2 The CORPS' Authorized Representative is Dorian Hasselmann, District Manager, 60 Plato Blvd E, Suite 210, Saint Paul, MN 55107, or their successor

INDEMNITY & INSURANCE REQUIREMENTS

- 7.1 To the fullest extent permitted by law, PROJECT HOST will defend, indemnify and hold harmless THE CORPS from any and all claims for bodily injury and property damage including the loss of use of property resulting therefrom, which arise or are in any way connected with the work performed, materials furnished or services provided by THE PROJECT HOST; THE PROJECT HOST's subcontractors or anyone employed directly or indirectly by any of them under this agreement as each party shall be responsible for its own acts and omissions and the results thereof to the extent authorized by law and shall not be responsible for the acts and omissions of the other party and the results thereof.
- 7.2 To the fullest extent permitted by law, THE CORPS will defend, indemnify and hold harmless PROJECT HOST from any and all claims for bodily injury and property damage including the loss of use of property resulting therefrom, which arise or are in any way connected with the work performed, materials furnished or services provided by THE CORP; THE CORPS's subcontractors or anyone employed directly or indirectly by any of them under this agreement as each party shall be responsible for its own acts and omissions and the results thereof to the extent authorized by law and shall not be responsible for the acts and omissions of the other party and the results thereof.
- 7.3 THE CORPS is not obligated to indemnify and defend PROJECT HOST or owner for claims due to the sole negligence or willful misconduct of PROJECT HOST. Any obligations assumed pursuant to this agreement will not be construed to negate, abridge or reduce other rights or obligations of indemnity, which otherwise exist as to a party or person described in this agreement.
- 7.4 THE PROJECT HOST is not obligated to indemnify and defend THE CORPS or owner for claims due to the sole negligence or willful misconduct of THE CORPS. Any obligations assumed pursuant to this agreement will not be construed to negate, abridge or reduce other rights or obligations of indemnity, which otherwise exist as to a party or person described in this agreement.
- 7.5 Applicable only if Corps staff or corps members will be operating motor vehicles owned, leased or rented by PROJECT HOST: The PROJECT HOST must provide THE CORPS certificates of insurance showing CONSERVATION CORPS MINNESOTA & IOWA as an Additional Insured for Automobile Liability and include a Waiver of Subrogation in favor of THE CORPS.

GOVERNING LAW, JURISDICTION, AND VENUE; FORCE MAJEURE

- 8.1 This contract shall be governed by the law applicable in the jurisdiction in which the services are performed.
- 8.2 For services performed in Minnesota, venue for all legal proceedings out of this contract, or its breach, must be in the appropriate state or federal court with competent jurisdiction in Ramsey County, Minnesota. In all other cases, venue

- for all legal proceedings out of this contract, or its breach, must be in the appropriate state or federal court with competent jurisdiction in the county in which the services are performed.
- 8.3 Neither party shall be liable for any failure to perform or delay in performance of this contract to the extent that any such failure arises from acts of God, war, civil insurrection or disruption, riots, pandemic, government act or regulation, strikes, lockouts, labor disruption, cyber or hostile network attacks, inability to obtain raw or finished materials, inability to secure transport, or any cause beyond such party's commercially reasonable control.
- 8.4 In no event shall either party be liable hereunder for incidental, special, indirect, consequential or punitive damages even if advised in advance of the possibility for such damages.

DUPLICATION, DISPLACEMENT, SUPPLANTATION

- 9.1 Conservation Corps is subject to the provisions of 42 U.S.C. §§ 12501 - 12682 and 45 C.F.R. parts 2500 - 2550. These laws require, in part, that AmeriCorps assistance not result in:
- 9.1.1 Duplication of an activity otherwise available in the locality of the program or would otherwise be performed by an employee as part of the employee's assigned duties.
- 9.1.2 Displacement of currently employed workers or workers on seasonal layoff or layoff from a substantially equivalent position, including partial displacement such as reduction in hours of non-overtime work, wages, or other employment benefits.
- 9.1.3 Termination or layoff of employees.
- 9.1.4 Infringement on the promotional opportunity of an employee or infringement on services performed by an employee as part of the employee's assigned duties.
- 9.1.5 Supplanting the hiring of employed workers.
- 9.1.6 Infringement on the assignments of any presently employed worker; an employee who recently resigned or was discharged; an employee who is on leave, on strike, being locked out, subject to a reduction in force, or has recall rights subject to a collective bargaining agreement or applicable personnel procedure.

AMERICORPS PROHIBITED SERVICE ACTIVITIES

- 10.1 Conservation Corps is subject to the provisions of 45 CFR § 2520.65.. While charging time to the AmeriCorps program, accumulating service or training hours, or otherwise performing activities supported by the AmeriCorps program or AmeriCorps, staff and members may not engage in the following activities:
- 10.1.1 Attempting to influence legislation;
- 10.1.2 Organizing or engaging in protests, petitions, boycotts, or strikes;
- 10.1.3 Assisting, promoting, or deterring union organizing;
- 10.1.4 Impairing existing contracts for services or collective bargaining agreements;
- 10.1.5 Engaging in partisan political activities, or other activities designed to influence the outcome of an election to any public office;
- 10.1.6 Participating in, or endorsing, events or activities that are likely to include advocacy for or against political parties, political platforms, political candidates, proposed legislation, or elected officials;
- 10.1.7 Engaging in religious instruction, conducting worship services, providing instruction as part of program that includes mandatory religious instruction or worship, constructing or operating facilities devoted to religious instruction or worship, maintaining facilities primarily or inherently devoted to religious instruction or worship, or engaging in any form of religious proselytization;
- 10.1.8 Providing a direct benefit to—
- (i) A business organized for profit;
- (ii) A labor union;
- (iii) A partisan political organization;
- (iv) A nonprofit organization that fails to comply with the restrictions contained in section 501(c)(3) of the Internal Revenue Code of 1986 except that nothing in this section shall be construed to prevent participants from engaging in advocacy activities undertaken at their own initiative;
- (v) An organization engaged in the religious activities described in paragraph (g) of this section, unless AmeriCorps assistance is not used to support those religious activities; and
- 10.1.9 Conducting a voter registration drive or using AmeriCorps funds to conduct a voter registration drive;
- 10.1.10 Providing abortion services or referrals for receipt of such services; and
- 10.1.11 Such other activities as AmeriCorps may prohibit.

AUTHORIZED REPRESENTATIVE**AUTHORIZED REPRESENTATIVE**

By:	By:
Title:	Title
Date:	Date:

CONSERVATION CORPS AUTHORIZED REPRESENTATIVE**AUTHORIZED REPRESENTATIVE**

By:	By:
Title: District Manager	Title:
Date:	Date:

CLEAN WATER FUNDS PROJECT REQUEST / SCOPE OF WORK

The CORPS and the PROJECT HOST have entered into an agreement to complete the project per the scope of work as derived from the originally submitted project request from:

Contact & Agency Information

1. Project Contact Name: Mattias Oddsson
2. Project Contact Title: Water Resources Engineer
3. Agency: City of Richfield
4. Phone Number: (612) 861-9797
5. Email Address: moddsson@richfieldmn.gov

Project Location Information & Description

1. Project Name: City of Richfield & RBWMO Rain Garden Program
2. Project Location: Rain gardens will be installed within the City of Richfield and will fall within the Minnehaha Creek Watershed, Richfield-Bloomington Watershed and Nine Mile Creek Watershed District. See attached map.
3. If applicable, project address: , Richfield, MN
4. Project Purpose: The City of Richfield and the Richfield-Bloomington WMO is collaborating Metro Blooms to install 12 new raingardens of an average of 150 square feet each. This is the first rain garden program for the City of Richfield and the Richfield-Bloomington WMO which seeks to improve water quality through the addition of residential scale rain gardens. Rain gardens are designed to meet the 1.1"/24 hour rain event, where possible.
The partners listed above are responsible for outreach and engagement of resident participants and promote the project locally through city newsletters and events. Residents are encouraged to attend local workshops led by Metro Blooms about rain gardens, healthy soil, turf alternatives and planting for pollinators. These workshops stress the importance of healthy landcare practices for water quality, including disconnecting point source runoff, such as roof and driveway runoff, from the municipal storm sewer system. Metro Blooms will manage the project, meet with participants, and conduct one-on-one consultations at each participant’s residence or property. At each consultation, Metro Blooms will educate participants on ways to reduce stormwater runoff, how to site rain gardens, and salt use reduction in winter. Metro Blooms then provides a rain garden design, orders plants, and oversees the Conservation Corps to excavate and mulch the rain gardens. Participants pick up their plants from a centralized location and plant their own raingarden. This increases the knowledge and personal investment of each participant in the maintenance of their new garden. All together, these raingardens are estimated to intercept 98,000 gallons of runoff annually.
5. Project Explanation: Crews are led by Metro Blooms’ Landscape Designer and/or Landscape Architect. Crews excavate rain gardens, amend the soil (if necessary), and place mulch. Metro Blooms identifies a location for soil disposal and the CCM crew delivers the soil/sod to the disposal site. CCM crew also picks up mulch from pre-determined site. The planting of the rain gardens will be completed by the participants. Metro Blooms will lead the crew in a training about the design, construction and maintenance of the gardens, stormwater conveyance, and proper erosion control practices at each site.

BMP To Be Installed & Priority Level

1. Urban landscaping – Raingarden, HIGH - New installation or establishment of BMPs
2. ,
3. ,

Pollution Reduction Estimate

Pollutant	Amount	Estimation Method
Phosphorous - est. reduction (lbs/yr)	.245	Other
Sediment - TSS (lbs/yr)	45	Other

Project Coordination & Scheduling

1. Detailed description and purpose of project, including desired outcomes:

The City of Richfield and the Richfield-Bloomington WMO is collaborating Metro Blooms to install 12 new raingardens of an average of 150 square feet each. This is the first rain garden program for the City of Richfield and the Richfield-Bloomington WMO which seeks to improve water quality through the addition of residential scale rain gardens. Rain gardens are designed to meet the 1.1"/24 hour rain event, where possible.

The partners listed above are responsible for outreach and engagement of resident participants and promote the project locally through city newsletters and events. Residents are encouraged to attend local workshops led by Metro Blooms about rain gardens, healthy soil, turf alternatives and planting for pollinators. These workshops stress the importance of healthy landcare practices for water quality, including disconnecting point source runoff, such as roof and driveway runoff, from the municipal storm sewer system. Metro Blooms will manage the project, meet with participants, and conduct one-on-one consultations at each participant’s residence or property. At

each consultation, Metro Blooms will educate participants on ways to reduce stormwater runoff, how to site rain gardens, and salt use reduction in winter. Metro Blooms then provides a rain garden design, orders plants, and oversees the Conservation Corps to excavate and mulch the rain gardens. Participants pick up their plants from a centralized location and plant their own raingarden. This increases the knowledge and personal investment of each participant in the maintenance of their new garden. All together, these raingardens are estimated to intercept 98,000 gallons of runoff annually.

2. Educational value and/or on-site education provided to crew: Metro Blooms will provide field training daily to crew members in site assessment, site planning, BMP installation, plant ID, weed ID and sustainable vegetation management. Specifically, crew members will be educated about the local watershed and will be given supplemental information about raingardens, the watersheds they are working in and the anticipated water quality improvements as a result of their work. Crew members are invited to attend any of Metro Blooms' alternative turf and resilient yards workshops free of charge. Metro Blooms Landscape Designers also spend at least 1 hour at the beginning of each neighborhood installation and when working with a new crew on the importance of rain gardens, how they are designed, as well as their specific pollution reduction impacts. Landscape Designers share planting plans with crew members, practice continual education as questions come up and provide printed materials to crew regarding rain gardens, maintenance and native plants. Sustainable Landcare Training will also be provided as part of the crew day, building on crew member interests in site assessment, site planning, BMP installation, plant ID, weed ID, and sustainable vegetation management.
3. Estimated Crew Time Required: 6
4. Preferred Season/Dates: Jun-Sept
5. Description of crew responsibilities and tasks to be carried out Crews are led by Metro Blooms' Landscape Designer and/or Landscape Architect. Crews excavate rain gardens, amend the soil (if necessary), and place mulch. Metro Blooms identifies a location for soil disposal and the CCM crew delivers the soil/sod to the disposal site. CCM crew also picks up mulch from pre-determined site. The planting of the rain gardens will be completed by the participants. Metro Blooms will lead the crew in a training about the design, construction and maintenance of the gardens, stormwater conveyance, and proper erosion control practices at each site.
6. List hand tools needed for the project: Sod kicker, wheelbarrows, shovels, Pulaski, hand pruners, loppers, hard rakes, brooms, scoop shovel, pitchfork, push brooms, blower and safety cones.
7. List power tools needed for the project: Truck, dump trailer and leaf blower.

Community Planning Information

1. Is all permitting, contracting, and landowner consent completed? No
 - a. If not, what is still required that may cause delay or cancellation of this project? No permitting is required for rain gardens on private property. For rain gardens to be installed in boulevards within the public right-of-way, Metro Blooms will procure necessary boulevard excavation permit. No delays are anticipated. Metro Blooms will procure any necessary consents and Boulevard Maintenance Agreements from participants where applicable for the City of Richfield. No delays or difficulties are anticipated in recruiting participants for this project or in construction of the rain gardens.
2. Has a TMDL implementation plan, watershed management plan, county comprehensive local water management plan, local surface water management plan, metro groundwater plan, surface water intake plan or well head protection plan been approved and locally adopted? Please explain: The City of Richfield Surface Water Management Plan addresses goals to integrate water resource management into public and private projects. Specific goals include:
 1. Maintain and enhance surface water quality to meet applicable standards and preserve ecological functions.
 2. Minimize the risk of flooding and associated negative impacts to public health, infrastructure, and the environment.
 3. Protect and preserve the quantity and quality of groundwater resources.
 4. Minimize erosion of soil into surface water systems and other negative environmental impacts of stormwater runoff.
 5. Protect and preserve fish and wildlife habitat and shoreland integrity.
 6. Preserve the quantity and quality of wetlands.
 7. Minimize public expenditures related to surface water management through effective planning, education, cooperation, and implementation.The City also supports the applicable rules and requirements of the MCWD, NMCWD, and RBWMO within each of their respective jurisdictions.
3. How will this project ensure practices implemented will be of a long-lasting public benefit with a minimum 10 years effective life? Participants agree to maintain their raingardens for 10 years, at a minimum. They also commit to educating any future owners about the rain garden, its benefits, purpose and maintenance. Metro Blooms provides printed and online maintenance information and resources, as well as maintenance consultations and services for hire.
4. Local financial contribution – itemized description and amount:

The City of Richfield and partners pay for project management, designs, installation oversight, mulch and soil dumping fees (if applicable), etc. Participants pay for consultations and plants.

City of Richfield: Approx. \$16,000
Project Participants: Approx. \$7,000



Report Prepared By:
Sam Crosby, City Planner

Department Director:
Melissa Poehlman, Community Development Director

Item for Consideration:
Site Plan Approval for conversion of a retail tenant space to a fitness studio at 6503 Nicollet Avenue South.

EXECUTIVE SUMMARY

Baleo Fitness has requested Site Plan Approval for a change of use for a 3,911 square foot tenant space in the Richfield Shoppes North from retail (formerly an Xfinity store) to a 24-hour fitness studio (Anytime Fitness). Health clubs or fitness centers are a permitted use in the zoning district, but the parking requirement is greater than for a shopping center, and the subject shopping center is already under-parked according to the Zoning Code.

Typically, a parking utilization study would be required. The initial inquiry started in late January. Due to the harsh winter conditions and Operation Metro Surge, staff agreed that a utilization study would produce inaccurate results. Therefore, only a parking analysis was conducted. The analysis concludes that, although the center does not have a parking surplus during its overall peak demand, there is a surplus during the fitness studio's peak hours, which compliment, rather than compete with, the center overall. Therefore, the proposed change of use is not expected to have a negative impact on the parking demand. Also, although they do not count according to the Zoning Code, there are five on-street stalls adjacent to the center on the south side of 65th Street.

Staff finds the analysis and its assumptions to be reasonable and that the proposal meets the intent of the Zoning Code to the extent practicable. The Planning Commission held a public hearing on Monday, April 27, 2026. No one from the public was in attendance. The Commission unanimously recommended approval as presented, including the installation of bike racks to help offset vehicle parking demand.

RECOMMENDED ACTION

By Motion: Approve the conversion of a 3,911 square foot tenant space from retail to a fitness studio.

HISTORICAL CONTEXT

- The subject site was constructed as a shopping center in the 1940s.
- The center is unique; the second and third story office space, which appears to have been added in the 1950s, is an early example of vertical mixed-use

development in a suburban community.

- In 2013, a Conditional Use Permit (CUP) was approved for a 4,200 square foot Class I (full service) restaurant (El Tejaban). A professionally prepared parking utilization study at that time demonstrated that off-street parking supply exceeded the demand due to varying peak hours of the tenant mix.
- In 2022, a CUP was approved for a Class III (fast food/convenience) restaurant (La Michoacana Tasty). Parking for food service users within shopping centers need not be calculated separately if certain conditions are met. Therefore, the parking study was not updated at that time.

EQUITABLE OR STRATEGIC CONSIDERATIONS OR IMPACTS

Equity

Twenty-four-hour fitness facilities increase access (particularly for individuals with non-traditional work hours) which can help reduce disparities in physical activity levels. However, if the membership fees are too high, the gym may be inaccessible to lower-income community members, limiting the benefits to more affluent groups.

Strategic Plan

The Strategic Plan includes desired outcomes of a vibrant downtown and a diversified tax base. It is desirable to have a range of commercial uses and peak hours in downtown, to help maintain vibrancy. A 24-hour fitness center may bring new visitors into downtown, who may stay and support surrounding businesses.

POLICIES (RESOLUTIONS, ORDINANCES, REGULATIONS, STATUTES, ETC.)

Parking

Based on zoning requirements of:

- 10 stalls per 1,000 for the 4,200 sq. ft. restaurant,
- 3.33 stalls per 1,000 for the 9,172 sq. ft. of upstairs office, and
- 4 stalls per 1,000 for the rest of the 52,945 sq. ft. shopping center, 285 stalls are required.

Applying the 10% reduction for being within a quarter mile of a frequently operating transit line lowers the total to 257. With 210 parking stalls provided, the site has a deficit of 47 stalls.

The parking code distinguishes between “community” shopping centers (under 50,000 sq. ft., requiring 3.5 stalls per 1,000 sq. ft.) and “regional” centers (over 50,000 sq. ft., requiring 4 stalls per 1,000 sq. ft.). Since the size of the subject center (even without the restaurant and upstairs space) is over 50,000 sq. ft., the regional number applies. While codes do need to draw a line somewhere, the subject shopping center appears to serve the immediate community, rather than drawing clientele from the surrounding region. Therefore, it could be argued that 3.5 stalls per 1,000 is a more accurate application, which would result in a 22 stall deficit.

The submitted parking analysis takes into consideration how the various businesses function throughout the day, including the hours of operation, and peak hours for each tenant. In short, because the peak hours of Anytime Fitness do not overlap with the overall peak hours of the rest of the center, Anytime Fitness is not expected to negatively impact the parking demand.

Finally, if parking becomes an issue, the business could structure its pricing to incentivize customers to visit during off-peak hours.

Traffic

The traffic generated by the change of use mimics the parking demand; as such, traffic is also not expected to be adversely impacted.

Zoning Compliance

Site Plan Approval is required in order to bring exterior improvements into conformance with current Zoning Code to the extent possible. The property currently has only one bike rack that does not meet code requirements for location or type. To reduce vehicle parking demand, staff recommends that the applicant install bicycle parking consistent with zoning requirements. Based on available information, this is 15 racks (30 bike parking “stalls”). Attached is a graphic that shows some areas where bike racks may fit, but an analysis must be done to determine how many can actually be installed given placement and clearance requirements. Also, given the limited space on site, staff recommends the applicant approach the City’s Public Works department, Hennepin County and/or Metro Transit in order to assess the possibility of locating bike racks within the public right-of-way.

The shopping center is nonconforming in regard to more than just vehicle and bike parking. Most notably, in relation to impervious area and hard-surface setbacks. Both the circulation aisle on the east side and the parking stalls on the west side encroach onto the adjacent right-of-way. Unfortunately, there is no practical remedy for these longstanding non-conformities.

Discretion

Site plan approval must be granted if the proposal meets performance standards. The City’s discretion is limited to evaluating compliance with established criteria.

CRITICAL TIMING ISSUES

60-DAY RULE:

- Application deemed complete: March 16, 2026.
- 60-day deadline: May 15, 2026.
- A decision is required by this date, or the City must notify the applicant that it is extending the deadline (up to a maximum of 60 additional days or 120 days total).

FINANCIAL IMPACT

None; all required application fees have been paid.

LEGAL CONSIDERATIONS

- Notice of the public hearing was published in the Sun Current on April 16, 2026, and mailed to properties within 350 feet of the site.
- After holding a public hearing on Monday, April 27, the Planning Commission unanimously recommended approval.

ALTERNATIVE RECOMMENDATION(S)

Approve with additional and/or modified stipulations.

Table the request until a parking utilization analysis has been conducted and the results provided.

Deny with findings that the proposal does not meet City requirements.

ATTACHMENTS

1. Anytime Fitness - SPA Reso (3)
2. Anytime Fitness - 6503 Nicollet Ave - Findings
3. Anytime Fitness Case Map
4. ATF Bike Parking Suggestions
5. Request for Review and Approval Letter_BaleoFitness
6. Floor Plan
7. 260311_Richfield Shoppes N_Parking Analysis

RESOLUTION NO. _____

**RESOLUTION APPROVING A SITE PLAN
FOR 6503 NICOLLET AVENUE SOUTH**

WHEREAS, an application has been filed by Baleo Fitness with the City of Richfield which requests site plan approval for a change of use for a 3,911 square foot tenant space in the Richfield Shoppes North from retail (Xfinity store) to a 24-hour (Anytime) fitness studio, property legally described as follows:

LOTS 1 THRU 15 INCLUSIVE EXCEPT THAT PART OF LOT 9 LYING SOUTH OF THE NORTH 49.00 FEET THEREOF AND EAST OF THE WEST 38.00 FEET OF SAID LOT 9 SUBJECT TO HIGHWAY.

WHEREAS, the Zoning Code Section 544.13, Subd.9, states that an applicant may request a modification of the minimum required number of parking spaces by submitting a study of anticipated parking demand; and

WHEREAS, the proposed site plan meets all other requirements necessary for granting site plan approval as specified in Zoning Code Section 547.13, Subd.8, as listed in the Required Finding Statement and as detailed in City Council Agenda Item No. ____; and

WHEREAS, Zoning Code section 509.25, Subd.7, requires that non-conforming site improvements be upgraded to comply with current code to the extent practical; and

WHEREAS, notice of the public hearing was mailed to properties within 350 feet of the subject property and published in the Sun Current newspaper on April 16, 2026; and,

WHEREAS, the Planning Commission of the City of Richfield held a public hearing at its April 27, 2026, meeting and recommended approval of the proposed site plan; and

WHEREAS, the City Council has fully considered the request for site plan approval;

NOW, THEREFORE, BE IT RESOLVED, by the City Council of the City of Richfield, Minnesota, as follows:

1. The City Council adopts as its Findings of Fact the **WHEREAS** clauses set forth above.
2. The City Council further adopts as its Findings of Fact the findings listed in the Required Findings Statement.

3. The proposed site plan is hereby approved subject to the following conditions:
- a. Separate sign permits are required.
 - b. All required parking spaces must remain available and un-obstructed year-round; they may not be used for snow storage.
 - c. The property owner is responsible for the ongoing maintenance of all exterior improvements in accordance with approved plans.
 - d. The applicant is responsible for obtaining all required permits and compliance with all other City, County, and State regulations.

Prior to the issuance of a building permit, the applicant shall:

- e. Provide final site plan with installation details, showing the location of 15 bike racks (30 bike parking stalls) for staff review and approval.

Prior to the issuance of a Certificate of Occupancy, the applicant shall:

- f. Enter into an escrow agreement for outstanding items and provide a surety equal to 125% of the value of any exterior improvements not yet complete, per Zoning Code Section 547.17.

Prior to the release of the surety:

- g. All exterior improvements shall be installed.
 - h. All requirements of the escrow agreement shall be met.
4. This approval shall expire one year from issuance unless the use for which the permit was granted has commenced, substantial work has been completed or upon written request by the applicant, the Council extends the expiration date for an additional period, as required by the Zoning Ordinance, Section 547.13, Subd. 9.

Adopted by the City Council of the City of Richfield, Minnesota this ____ day of May, 2026.

Mary B. Supple, Mayor

ATTEST:

Michelle Friedrich, City Clerk

Required Findings
Anytime Fitness / 6503 Nicollet Avenue South

Site Plan Approval (Subsection 547.13) In evaluating a site plan, the Planning Commission and Council shall consider its compliance with the following:

- a) *Consistency with the various elements and objectives of the City's long range plans including, but not limited to, the Comprehensive Plan.*
 - The proposed site is not included in any small area or other long-range plans separate from the Comp Plan. The use is consistent with the 2040 Comprehensive Plan.
- b) *Consistency with the purposes of the Zoning Code.*
 - The proposed use is allowed in the C-2 zoning district, however the parking does not meet the City's current requirements. Zoning Code Section 544.13, Subd.9, states that an applicant may request a modification of the minimum required number of parking spaces by submitting a study of anticipated parking demand. The request is not a formal variance and therefore the variance review criteria do not apply. The analysis was done by a professional engineer with expertise in traffic and parking analysis, and was based on Institute of Transportation Engineering (ITE) parking research. The analysis indicates that, due to the off-set in peak hours of the various uses within the center, the anytime fitness will not have a negative impact on the parking demand. Therefore, staff finds that the proposed change of use is consistent with the purpose of the Zoning Code.
- c) *Preservation of the site in its natural state, insofar as practicable, by minimizing tree and soil removal, and designing any grade changes so as to be in keeping with the general appearance of neighboring areas.*
 - N/A; no external changes are proposed.
- d) *Creation of a harmonious relationship of buildings and open spaces with the terrain and with existing and future buildings having a visual relationship to the proposed development.*
 - The building is existing and no external changes are proposed.
- e) *Creation of a functional and harmonious design for structures and site features including:*
 - i. *Creation of an internal sense of order for the various functions and buildings on the site and provision of a desirable environment for occupants, visitors, and the general community;*
 - The site layout is existing, no external changes are proposed.
 - ii. *Appropriateness of the amount and arrangement of open space and landscaping to the design and function of the development;*
 - No changes to the site layout are proposed.
 - iii. *Appropriateness of the materials, textures, colors and details of construction as an expression of the design concept of the project and the compatibility of the same with the adjacent and neighboring structures and functions;*
 - The building is existing with no changes.
 - iv. *Adequacy of vehicular, cycling and pedestrian circulation, including walkways, interior drives and parking, in terms of location and number of access points to the public streets, width of interior drives and access points, general interior circulation, separation of pedestrian, cycling and vehicular traffic and arrangement and amount of parking so as to be safe, convenient and, insofar as practicable, compatible with the design of proposed buildings, structures and neighboring properties.*

- No external changes are proposed. However, the addition of bike racks will enhance the ease of biking to the shopping center, which will help to alleviate the parking demand.
- The arrangement of access (both vehicular and non-vehicular) and parking is generally safe, convenient and compatible with surrounding properties.

f) *Creation of an energy-conserving design through design, location, orientation and elevation of structures, the use and location of glass in structures, and the use of landscape materials and site grading.*

- No external changes are proposed.

g) *Protection of adjacent and neighboring properties through reasonable provisions for such matters as surface water drainage, sound and sight buffers, preservation of views, light and air, and those aspects of design, not adequately covered by other regulations, which may have substantial effects on neighboring land uses.*

- No external changes are proposed.



6503 Nicollet Avenue South

Location and Zoning Map

Richfield Shoppes North - Anytime Fitness

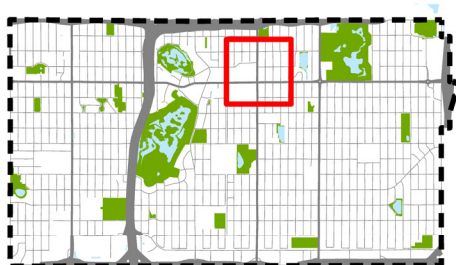
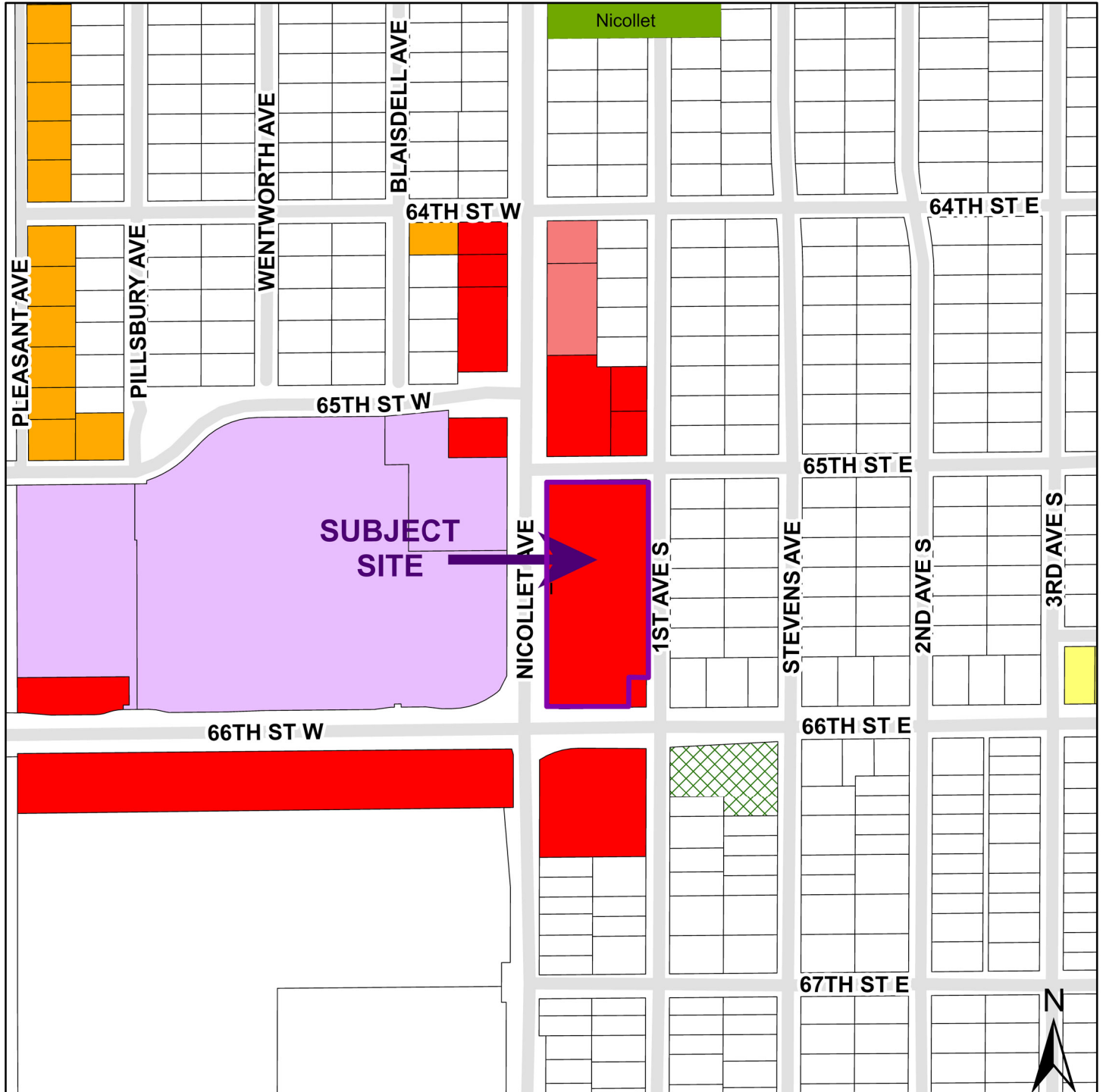

Legend

- | | | |
|-------------------------------|---------------------------------|-----------------------|
| R Low Density Residential | C-1 Neighborhood Business | PMU Planned Mixed Use |
| R-1 Single Family Residential | C-2 General Commercial | Parks |
| MR-2 Multi-Family | PC-2 Planned General Commercial | City Limit |

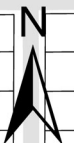
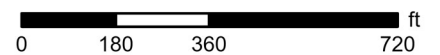



Expand curb to maximize space.



Would need to remove boulders. Also requires permit from City for ROW feature. Slight risk of removal without compensation if City ever needs to do any work in this area in the future.

6503



Need to maintain 6 foot wide ped path.

Requires approval by Metro Transit.

Requires approval by Hennepin County



16

STAVES

STAVES

S

**Request for Review and Approval
Anytime Fitness Relocation to Richfield Shoppes**

Dear City of Richfield Planning Staff,

My name is John Christopher, and I am the CEO of Baleo Fitness, an Anytime Fitness franchise operator. We currently operate 13 Anytime Fitness clubs across the Twin Cities, and we take pride in creating community-based coaching gyms that support the health and wellness of the neighborhoods we serve.

We are submitting this application in connection with the relocation of our existing Richfield Anytime Fitness location. Unfortunately, the lease for our current club located in the Richfield Target Plaza will be ending on June 1, which would otherwise leave approximately 700 local members without a home gym and disrupt the jobs of our local team.

Our goal is to relocate the club to Suite 6503 within Richfield Shoppes, a space previously occupied by Xfinity. The proposal involves no expansion of the building, no parking variance and no changes to the site, simply the replacement of an existing tenant within the shopping center.

We are hopeful to move this process forward as efficiently as possible so we can open the new location by June 1 and provide continuity for both our members and our team. Maintaining that continuity is extremely important to us and to the community we serve.

We appreciate your time and consideration and look forward to working with the City of Richfield throughout the review process.

Warm regards,

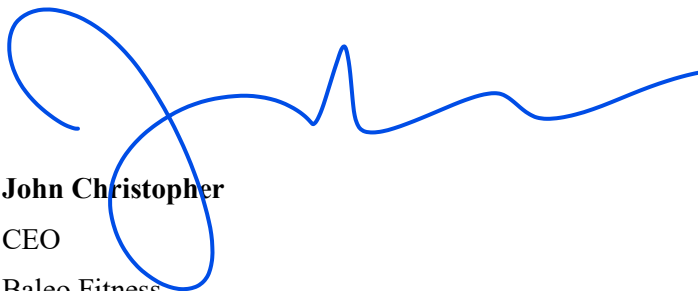

John Christopher

CEO

Baleo Fitness

Anytime Fitness Operator

NOTE: This layout/design was created utilizing existing condition/as-built information supplied by the Franchisee and/or their consultant. This document is not intended for permitting or construction. The franchisee is responsible to contract with a licensed architect, a.k.a. Architect of Record (AOR), to create code compliant construction drawings, based on this design. Verify all dimensions in field and notify the AOR of any discrepancies prior to starting construction.

- GENERAL NOTES:**
- Interior door & window frames (excluding storefront) to be painted to match the adjacent wall color.
 - All electrical and low voltage wiring to include MyZone and HDMI cables to be run in wall - no exposed conduit or cables allowed.
 - All new gyp. bd. walls need a level 4 finish before applying paint & other finish materials. No textured walls allowed.
 - All new wall receptacles & switches to have gray devices & cover plates.
 - No outlets, switches, thermostats, emergency lights or other devices to be located on branded walls/elements: member lobby feature wall, face of office, lightbox wall, AF training station and shall be placed as directed on the compliance drawing when specifically shown.
 - Vinyl wall graphics cannot be installed on textured walls. Painted walls receiving graphics must cure for 14 days before the graphics are applied.
 - Wall mounted devices cannot encroach on wall graphics and signage, lights, alarms, cameras, etc.
 - Owner responsible to ensure club meets all applicable requirements and codes.
 - Minimum allowable ceiling height for main club area is 10'-0"; ceiling must be white.
 - Gyp. bd. ceilings are required in all restrooms & tanning rooms. If walls extend to deck, a vinyl wrapped acoustical ceiling system can be used.
 - Contractor and owner are responsible for verifying existing conditions.

This layout is for reference only. Provide the Permit Approved Construction Document set to vendors to ensure the most accurate proposals. Verify all measurements & quantities received on proposals.

DRAWING KEY:

	= EXISTING WALL
	= NEW WALL
	= DEMO WALL
	= EXISTING DOOR
	= EXISTING DOOR; MAY NOT BE REQUIRED
	= NEW DOOR
	= DEMO DOOR
	= FLOOR TRANSITION

FINISH FLOOR KEY:

	RUBBER
	CARPET
	TURF
	OTHER FLOORING AS NOTED

1st Time FZ: Yes No

NEW CLUB COMPLIANCE DRAWING
 Page 10 of 103
 FLOOR PLAN

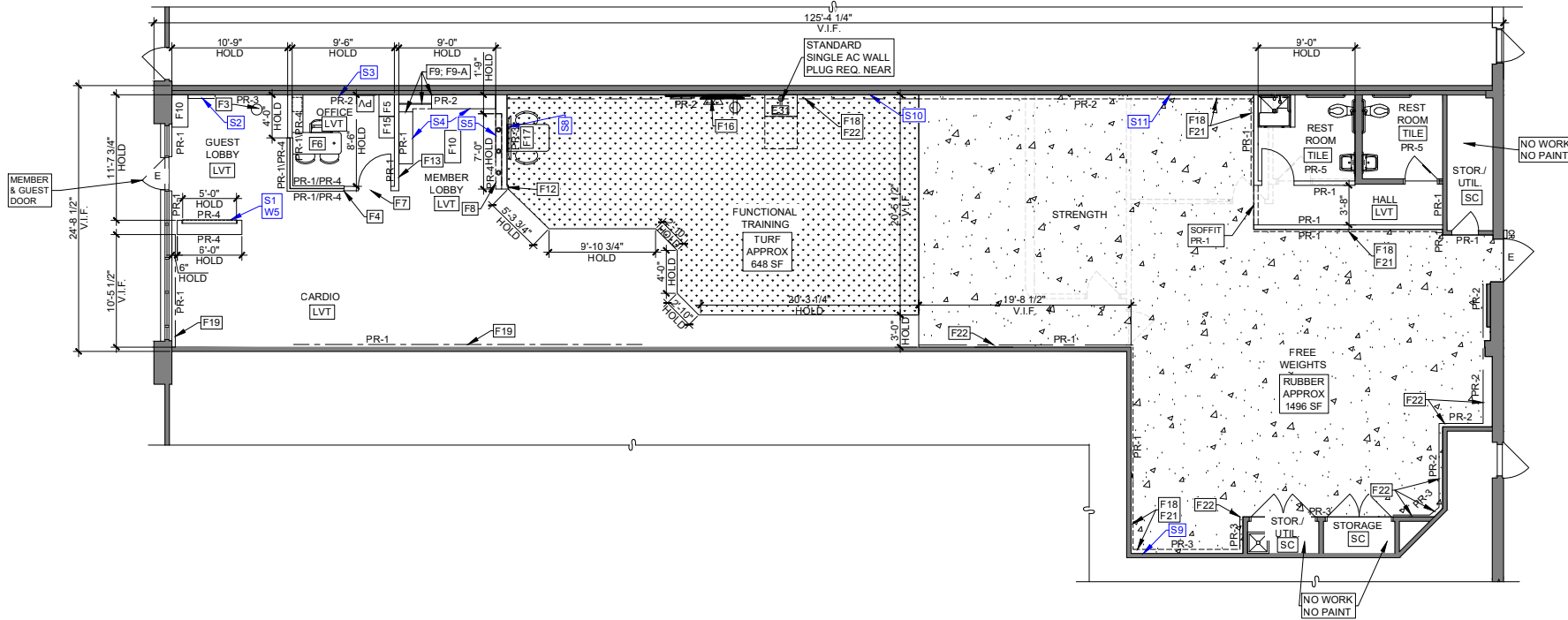

KEYED NOTES: REFER TO DESIGN COMPLIANCE PACKET (DCP) FOR CONSTRUCTION DETAILS & ADDITIONAL INFORMATION; **CROSSED OUT NOTES ARE NOT USED IN THIS PROJECT**

FIXTURES, FURNISHINGS & EQUIPMENT

- F1- GUEST LOBBY DECORATIVE LIGHTING
- F2- GREEN WALL
- F3- GUEST WAIVER STAND
- F4- FRAMELESS OFFICE WINDOW
- F5- PRINTER STAND - OPTIONAL
- F6- OFFICE DESK & CHAIRS
- F7- FULL GLASS DOOR REQUIRED
- F8- MEMBER LOBBY FEATURE WALL & DISPLAY PANEL
- F9- CUBBIES/CUBBY LEGS
- F9A- RIVER ROCK BOOT TRAY OR MAT BOOT TRAY
- F10- GUEST/MEMBER LOBBY BENCH
- F11- MEMBER LOBBY DECORATIVE LIGHTING

FIXTURES, FURNISHINGS & EQUIPMENT CONTINUED

- F12- INTENTIONAL BUMP OUT FOR PAINT CHANGE - REQUIRED
- F13- LOCATION OF EMERGENCY PHONE/EQUIP; 2'-6" MIN. - REQUIRED
- F14- COACHING TABLE & CHAIRS
- F15- EVOLT
- F16- AF TRAINING COMMUNICATION TELEVISIONS
- F17- AF TRAINING STATION TABLE, CHAIRS, & TV
- F18- LINE INDICATES RECOMMENDED LOCATION OF MIRRORS
- F19- RUN ELECTRICAL FOR CARDIO ALONG STOREFRONT OR IN WALL
- F20- LINE INDICATES TO RUN ELECTRICAL FOR SECOND ROW OF GARDIO
- F21- FREE WEIGHT WALL PROTECTION (UNDER MIRROR) - RECOMMENDED
- F22- OTHER WALL PROTECTION - RECOMMENDED
- F23- RECOVERY FURNITURE
- E31- HYPERICE PERCUSSION THERAPY - REQUIRED

INTERIOR SIGNAGE & GRAPHICS

- S1- LIGHTBOX FEATURE WALL & GRAPHIC
- S2- LIT/NON-LIT MONOGRAM SIGN
- S3- OFFICE LOGO SIGN
- S4- CUBBY SIGNS
- S5- ERASE BOARD & DOC HOLDERS
- S6- COACHING ROOM GRAPHIC
- S7- COACHING ROOM POSTERS/HOLDERS
- S8- TRAINING STATION GRAPHIC
- S9- AF FREE WEIGHT MONOGRAM
- S10- YOU'VE GOT THIS GRAPHIC
- S11- MUSCLE GRAPHIC
- S12- AF GRAPHIC
- S13- RECOVERY POSTER
- S14- RECOVERY DOOR GRAPHIC

COMMONLY USED ABBREVIATIONS

- CA = CARPET FLOOR
- TILE = CERAMIC TILE FLOOR
- LVT = LUXURY VINYL TILE FLOOR
- RF = RUBBER FLOOR
- TURF = ECORE TURF FLOOR
- LVP = LUXURY VINYL PLANK FLOOR
- STC = STAINED CONCRETE FLOOR
- XC = EXISTING FLOORING TO REMAIN
- PR-1 - PR-10 = WALL PAINT COLOR
- PV - PROVISION EQUIPMENT

PAINT SCHEDULE

KEY	PAINT NUMBER AND NAME	KEY	PAINT NUMBER AND NAME
PR-1	SW 7662 Evening Shadow		
PR-2	SW 9161 Dustblu	PR-7	SW 9162 African Gray
PR-3	SW 7076 Cyberspace	PR-8	SW 7005 Pure White
PR-4	New AF Purple (Custom)	PR-9	SW 7006 Extra White
PR-5	SW 7649 Silverplate	PR-10	B42W00082 White (Ceiling)



PROJECT LOCATION: RICHFIELD, MN AF3192 - APPROX. SF 3,482
 ADDRESS: 6401 RICHFIELD PKWY, RICHFIELD, MN 55423

Square footage shown is a graphic representation based on the data received and may vary from the square footage as defined in the lease.

DESIGN MANUAL - REAL AF DESIGN SCHEME: REAL AF

REV:	DESCRIPTION:	DATE:
-	ORIG. LAYOUT DATE	02/24/2026
	LAYOUT VALID UNTIL	08/24/2026

REV:	DESCRIPTION:	DATE:

PARKING ANALYSIS

Richfield Shoppes

Richfield, MN

MARCH 11, 2026

PREPARED FOR:

Baleo Fitness

Chicago, Illinois

PREPARED BY:

Westwood

Parking Analysis

Richfield Shoppes

Richfield, Minnesota

Prepared For:

Crys Peyton
Baleo Fitness
2136 W Schiller St., Unit 3,
Chicago, IL 60622
803-236-7628

Prepared By:

Brandi Swanson, P.E.
Westwood Professional Services
12701 Whitewater Drive, Suite 300
Minnetonka, MN 55343
(952) 937-5150

"I certify that this Parking Analysis has been prepared by me or under my immediate supervision and that I have experience and training in the field of traffic and transportation engineering."

Brandi Swanson

3/11/2026

Minnesota Professional Engineering License 64424

Exp: 6/30/2026

Project Number: R0077789.00

Date: March 11, 2026

Revision Notes

Rev No.	Issue Date	Prepared by	Reviewed by	Description
0	2/11/2026	BNS	CRF	Initial Submittal
1	2/13/2026	BNS	CRF	Modification of Leasable Area
2	3/11/2026	BNS	CRF	City Comments

Table of Contents

- 1.0 Executive Summary 3**
- 2.0 Background 4**
 - 2.0 Roadway Data.....4
 - 2.2 Land Use Data.....4
- 3.0 Shared Parking Analysis7**
 - 3.1 City of Richfield Zoning Code.....9
 - 3.2 ITE Parking Generation10
- 4.0 Conclusion..... 13**

Tables

- Table 2.1: Roadway Data..... 4**
- Table 2.2: Richfield Shoppes Land Use..... 6**
- Table 3.1: Richfield Shoppes Hours of Operation 8**
- Table 3.2: City Parking Requirements Assuming Full Occupancy 11**
- Table 3.3: ITE Parking Generation Assuming Full Occupancy 11**

Figures

- Figure 1 – Site Location 4**
- Figure 2 – Parking Stall Count12**

Appendices

Appendix A: City of Richfield, MN Zoning Code Section 544

1.0 Executive Summary

Westwood Professional Services, Inc. (Westwood) has been retained by Baleo Fitness to prepare a Parking Analysis for the Richfield Shoppes located at the northeast quadrant of the intersection of E 66th Street and Nicollet Avenue in Richfield, MN. The Richfield Shoppes project includes Anytime Fitness replacing an existing unit within Richfield Shoppes.

This report includes an analysis of the existing parking needs for Richfield Shoppes.

This analysis was conducted utilizing the Institute of Transportation Engineering (ITE) *Parking Generation Manual, 6th Generation* and following the *City of Richfield Zoning Codes*.

FINDING:

The existing Richfield Shoppes does not meet the minimum parking demand as defined by ITE rates or minimum parking demand as defined by the City of Richfield Zoning Code when analyzing for full occupancy.

The Richfield Shoppes Peak Hour from 1:00 pm – 2:00 pm demands more parking stalls than the 210 stalls currently available for both ITE and City code when analyzing for full occupancy.

Richfield Shoppes Peak Hour (1:00 – 2:00 pm) Parking Stall Demand

Method	Peak Hour Demand	Deficit
City Code	255	45 Stalls
ITE	211	1 Stall

FINDING:

The proposed Anytime Fitness has a weekday peak hour of 5:00 pm – 6:00 pm. During this peak hour, Richfield Shoppes has a surplus of parking stalls when including the Anytime Fitness and using City and ITE rates.

Since the peak hour of Anytime Fitness does not overlap with the overall peak hour of the development, Anytime Fitness is not expected to negatively impact the parking demand at Richfield Shoppes.

Anytime Fitness Peak Hour (5:00 – 6:00 pm) Parking Stall Demand

Method	Peak Hour Demand	Surplus
City Code	200	10 Stalls
ITE	177	33 Stalls

FINDING:

Anytime Fitness does not change the parking demand for Richfield Shoppes at full occupancy compared to the previous Xfinity store.

2.0 Background

The project site is located at the northeast quadrant of the intersection of E 66th Street and Nicollet Avenue. The project is located south and east of IH-35W in Richfield, Minnesota. See **Figure 1** for the site location.

Figure 1 – Site Location

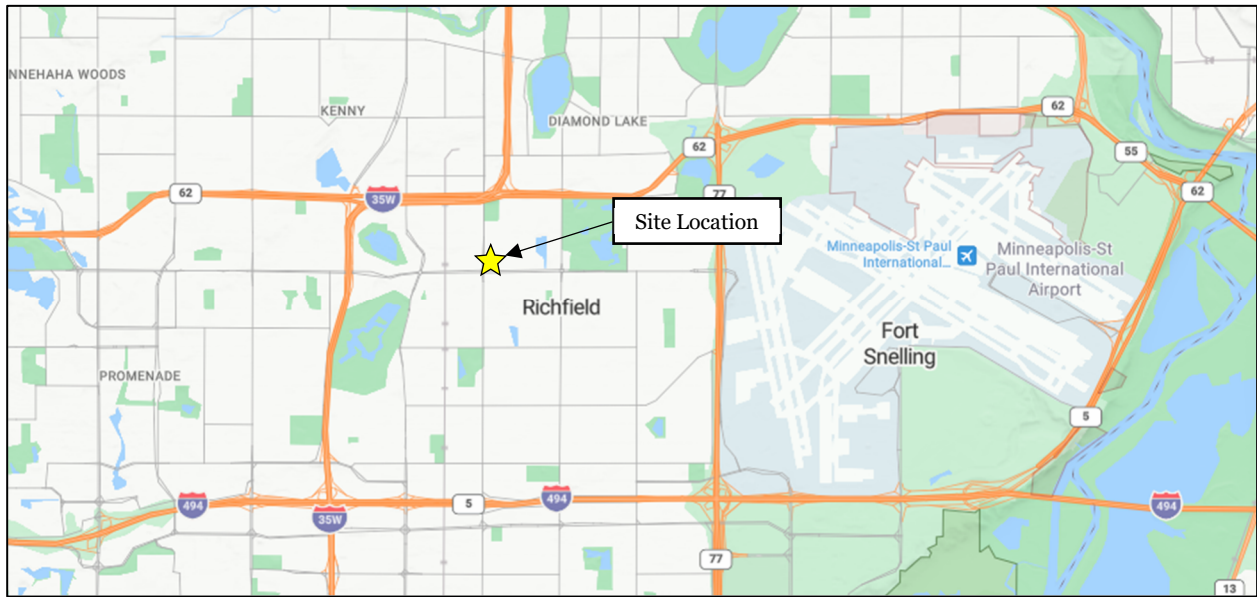

Source: Bing Maps

2.0 Roadway Data

Roadway data is as follows:

Table 2.1: Roadway Data

Roadway	Classification ¹	Speed Limit ²	AADT ³	Bike Lane ⁴	Transit Route ⁵
E 66th St.	Minor Reliever	35 mph	13,323	Offset	Bus
Nicollet Ave.	Minor Augmentor	35 mph	8,577	On Roadway	Bus

- (1) Source: MNDOT Functional Classification System Map: Twin Cities Metropolitan Area 2025.
- (2) Source: Google street view
- (3) AADT = Annual Average Daily Traffic. Source: MNDOT Traffic Mapping Application for 2024 counts.
- (4) Source: City of Richfield Bicycle Map – August 2025 Update
- (5) Source: Twin Cities Metropolitan Area Transit System Map Effective 10/6/25.

2.2 Land Use Data

The existing Richfield Shoppes is a mixed-use development consisting of approximately 57,145 SF of retail and 9,172 SF of second and third floor office space. Currently, approximately 8,000 SF of retail and 3,200 SF of second and third floor office space is vacant. The site also contains a Dairy Queen restaurant in a separate building located in the southeast corner of the property that provides “walk-up” window service and does not have indoor customer seating areas.

The proposed Anytime Fitness is looking to move into 6503 Nicollet Avenue, which was most recently occupied by Xfinity within Richfield Shoppes. The space is 3,911 SF.

2.2.1 Richfield Zoning Code

Subsection 544.13 of the Richfield Zoning Code discusses vehicle parking requirements for off-street parking (**Appendix A**). The number of parking stalls required is categorized by different

land uses. Per discussion with the City of Richfield, the first floor of Richfield Shoppes should be considered the shopping center, while the second and third floor should be considered office space. Within Subsection 544.13 Subd. 6, parking requirements are separated by subcategories for Office, Shopping Center, and Restaurants.

The main floor of Richfield Center is classified as Shopping Center – Regional (over 50,000 SF), with the exception of one restaurant. The restaurant does not meet the requirements described by the City Zoning Code to be included in the Shopping Center land use and is therefore classified as Class I & II Restaurants. The Dairy Queen is included within the Shopping Center.

The second and third floor of Richfield Shoppes is classified as Office – Floor Area of Less than 50,000 Square Feet.

See **Table 2.2** for a summary of the land use.

2.2.2 ITE Land Use Code

ITE describes the Land Use Code (LUC) 821 – Shopping Plaza (40-150k) as “an integrated group of commercial establishments planned, developed, owned, and managed as a unit.” The land use has a subcategory of including or not including a supermarket and “common tenants include office space, a movie theater, restaurants, a post office, banks, a health club, and recreational facilities.” The first, second, and third floors of Richfield Shoppes will be classified as LUC 821 – Shopping Plaza (40-150k) – Without Supermarket.

ITE describes LUC 933 – Fast-Food Restaurant without Drive-Through Window as including “any fast-food restaurant without a drive-through window” and the “limited-service eating establishments do not offer table service.” The Dairy Queen will be classified as LUC 933 – Fast-Food Restaurant without Drive-Through Window.

See **Table 2.2** for a summary of the land use.

2.2.3 Land Use Data Summary

The land uses and associated addresses for Richfield Shoppes described in **Section 2.2.1**, **Section 2.2.2** are summarized in **Table 2.2**. Business names, square footage, and hours of operation were provided by Mid-America Real Estate – Minnesota, LLC.

Table 2.2: Richfield Shoppes Land Use

Suite #	Business	Gross Area	ITE Land Use ¹	City Land Use ¹	Hours of Operation ²		
6501	Aqua Coin Laundromat	3,113 SF	821	SC	24 Hours		
6503	Anytime Fitness	3,911 SF	821	SC	24 Hours		
6505	National Cremation Society	2,200 SF	821	SC	24 Hours		
6507	H&R Block	2,239 SF	821	SC	9:00 AM	-	8:00 PM
6509	Gift Jewelers	1,937 SF	821	SC	1:00 PM	-	7:00 PM
6511	AVAILABLE	2,600 SF	821	SC	8:00 AM	-	5:00 PM
6515	Rong Market	7,304 SF	821	SC	9:00 AM	-	8:00 PM
6517	New Life Family Services	4,796 SF	821	SC	9:00 AM	-	5:00 PM
6519	El Tejaban Mexican Restaurant	4,200 SF	821	R1&2	7:00 AM	-	2:00 PM
6521	Atlas Staffing	2,890 SF	821	SC	6:00 AM	-	5:00 PM
6523	AVAILABLE	2,350 SF	821	SC	8:00 AM	-	5:00 PM
6525	Boost Mobile	1,465 SF	821	SC	10:00 AM	-	8:00 PM
6527	American Pie	1,895 SF	821	SC	10:00 AM	-	2:00 AM
6533	Auto Zone	7,134 SF	821	SC	8:00 AM	-	9:00 PM
6535	AVAILABLE	3,050 SF	821	SC	8:00 AM	-	5:00 PM
4	La Michoacana Tasty	2,816 SF	821	SC	10:00 AM	-	10:00 PM
8	Mary's Glamour Salon	1,276 SF	821	SC	9:00 AM	-	8:00 PM
10	Subway	759 SF	821	SC	9:00 AM	-	8:00 PM
12	V Spa Nails	1,210 SF	821	SC	10:00 AM	-	7:30 PM
16	Dairy Queen	1,000 SF	933	SC	11:00 AM	-	9:00 PM
201	State Farm	1,998 SF	821	Office	9:00 AM	-	5:00 PM
202	AVAILABLE	993 SF	821	Office	8:00 AM	-	5:00 PM
205	AVAILABLE	1,595 SF	821	Office	8:00 AM	-	5:00 PM
300	AVAILABLE	678 SF	821	Office	8:00 AM	-	5:00 PM
301	City Traveler	2,090 SF	821	Office	9:00 AM	-	5:00 PM
303	Murdoch Orthodontics	1,818 SF	821	Office	7:30 AM	-	4:00 PM

(1) See below for the explanation of Land Use

821 ITE LUC 821 – Shopping Plaza (40-150k) – Without Supermarket

933 ITE LUC 933 – Fast Food Restaurant without Drive-Through Window

SC City of Richfield Zoning Code Shopping Center – Regional (50,000 SF or More)

R1&2 City of Richfield Zoning Code Class I & II Restaurants

Office City of Richfield Zoning Code Office – Floor Area of Less than 50,000 Square Feet

(2) Hours of Operation are anticipated to be 8:00 am – 5:00 PM for AVAILABLE suites.

3.0 Shared Parking Analysis

A Shared Parking Analysis should be conducted when a site has a mixture of different land uses to determine if the peak parking demands for the various on-site land uses conflict or complement each other. Shared parking occurs when the same parking area services two or more land uses without conflict. The success of shared parking relies on the variations of parking demands between the site's individual land uses, as well as the relationships between the individual land uses that allow motorists to visit more than one land use during a single visit to the site and/or visit different land uses at different times of the day.

Baleo Fitness provided one year of data for visits to their existing Richfield location. The weekday peak hours for their existing location were calculated to be 6:00 am – 7:00 am and 5:00 pm – 6:00 pm, with the highest visits seen on Tuesday. The weekend peak hour is 9:00 – 10:00 am, where Saturday is more popular than Sunday.

Table 3.1 below shows a time chart for the hours of operation for each business in Richfield Shoppes.

ITE provides time-of-day parking distributions for certain land uses, which is utilized within this report to anticipate the peak hour of each land use.

Understanding the time-of-day parking demand distribution will help to determine if the peak parking demand of the proposed Anytime Fitness overlaps with the peak parking demand of the existing shopping center. The time-of-day distribution for Richfield Shoppes' parking demand was determined by applying the most appropriate ITE parking time-of-day distribution to the land uses associated with the city's parking requirements.

Table 3.1: Richfield Shoppes Hours of Operation

Suite #	12 AM	1 AM	2 AM	3 AM	4 AM	5 AM	6 AM	7 AM	8 AM	9 AM	10 AM	11 AM	12 PM	1 PM	2 PM	3 PM	4 PM	5 PM	6 PM	7 PM	8 PM	9 PM	10 PM	11 PM	
6501																									
6503																									
6505																									
6507																									
6509																									
6511																									
6515																									
6517																									
6519																									
6521																									
6523																									
6525																									
6527																									
6533																									
6535																									
4																									
8																									
10																									
12																									
16																									
201																									
202																									
205																									
300																									
301																									
303																									

Hours of Operation are Assumed
 Hour of Operation Provided by Mid-America Real Estate – Minnesota, LLC.
 Anytime Fitness Peak Hours

3.1 City of Richfield Zoning Code

Richfield, Minnesota's Zoning Code includes parking standards in Subsection 544.13 and can be found in **Appendix A**. Parking rates were calculated for the land uses described in **Section 2.2.1**. The off-street parking requirements for Shopping Center, Class I & II Restaurants, and Office are prescribed within the zoning code. It should be noted that the City Zoning Code allows for a decrease in 10% of the parking required when the location is in close proximity to an active transit line. The reduction applies to this development.

The parking demand was then applied to the most appropriate ITE time-of-day parking distributions to calculate the parking demand of the entire parking lot: Shopping Center utilized ITE LUC 820 – Shopping Center, Class I & II Restaurants utilized ITE LUC 932 – High-Turnover (Sit Down) Restaurant, and Office utilized ITE LUC 710 – General Office Building.

Table 3.2 shows the parking demand based on the City of Richfield's Zoning Code, the demand parking of Richfield Shoppes throughout the day, and the stall surplus/deficit for each hour.

Parking Demand

Based on City Zoning Code, Richfield Shoppes has a demand of 261 parking stalls. Richfield Shoppes currently has 210 parking stalls (**Figure 2**).

Parking Lot Surplus/Deficit

When breaking out the development by land use and associated peak hour:

- the peak parking demand of Richfield Shoppes at full occupancy is 1:00 pm – 2:00 pm at 255 stalls, with a deficit of 45 stalls
- the parking demand for the peak hour of Anytime Fitness, from 5:00 pm – 6:00 pm is 200 stalls, which is a 10-stall surplus.

3.2 ITE Parking Generation

ITE Parking Generation rates were utilized for the two land uses described in **Section 2.2.2**, and the demand was applied to the ITE time-of-day parking distributions to calculate the parking demand of the entire lot: ITE LUC 821 – Shopping Plaza utilized ITE LUC 820 – Shopping Center as there is not available time-of-day data for ITE LUC 821, ITE LUC 933 – Fast-Food Restaurant without Drive-Through Window utilized ITE LUC 934 – Fast-Food Restaurant with Drive-Through Window as there is not available time-of-day data for ITE LUC 933.

Table 3.3 shows the parking demand calculated based on ITE resources, the parking demand of Richfield Shoppes throughout the day, and the stall surplus/deficit for each hour. The peak parking demand of Richfield Shoppes at full occupancy is 1:00 pm – 2:00 pm and does not conflict with the peak hour of Anytime Fitness from 5:00 pm – 6:00 pm.

Parking Demand

Utilizing ITE Parking Generation rates, Richfield Shoppes has a demand of 212 parking stalls. Richfield Shoppes currently has 210 parking stalls (**Figure 2**).

Parking Lot Surplus/Deficit

When breaking out the development by land use and associated peak hour:

- the peak parking demand of Richfield Shoppes at full occupancy is 1:00 pm – 2:00 pm at 211 stalls, with a deficit of 1 stall.
- the parking demand for the peak hour of Anytime Fitness, from 5:00 pm – 6:00 pm is 177 stalls, which is a 33-stall surplus.

Table 3.2: City Parking Requirements Assuming Full Occupancy

Land Use	Area	Existing Parking Stalls	City Requirements		Hourly Shared Parking Demand Based on ITE Standards Average Weekday															
			Rate	Peak Parking Demand	7 AM	8 AM	9 AM	10 AM	11 AM	12 AM	1 PM	2 PM	3 PM	4 PM	5 PM	6 PM	7 PM	8 PM	9 PM	10 PM
Shopping Center – Regional (50,000 SF or More)	53,705 SF	210	4 per 1,000 SF	215	-	32	69	116	153	213	215	194	178	174	181	185	172	135	90	32
Class I & II Restaurant	4,200 SF		10 per 1,000 SF	42	-	-	-	11	18	40	40	20	16	16	26	42	42	36	21	12
Office (Floor Area Less than 50,000 SF)	9,172 SF		1 per 275 SF	33	4	16	29	33	33	28	28	31	28	28	15	7	4	-	-	-
10% Reduction for Close Proximity to Active Transit Line			10% Reduction	-29	0	-5	-10	-16	-20	-28	-28	-25	-22	-22	-22	-23	-22	-17	-11	-4
Totals		210	Per City Requirements	261																
Total Shared Parking Demand					4	43	88	144	184	253	255	220	200	196	200	211	196	154	100	40
Total Shared Supply					210	210	210	210	210	210	210	210	210	210	210	210	210	210	210	210
Total Shared Parking Surplus/(Deficit)					206	167	122	66	26	(43)	(45)	(10)	10	14	10	(1)	14	56	110	170

= Represents the peak parking demand hour of the Richfield Shoppes
 = Represents the peak hour of Anytime Fitness

Table 3.3: ITE Parking Generation Assuming Full Occupancy

Land Use	Area	Existing Parking Stalls	ITE Parking Demand		Hourly Shared Parking Demand Based on ITE Standards Average Weekday															
			Rate	Peak Parking Demand	7 AM	8 AM	9 AM	10 AM	11 AM	12 AM	1 PM	2 PM	3 PM	4 PM	5 PM	6 PM	7 PM	8 PM	9 PM	10 PM
821 - Shopping Plaza (40-150k) - No Supermarket	66,317 SF	210	3.11 per 1,000 SF	206	-	31	66	111	146	204	206	185	171	167	173	177	165	130	87	31
933 - Fast-Food Restaurant without Drive-Through Window	760 SF		7.54 per 1,000 SF	6	-	-	-	2	4	6	5	3	3	3	4	4	1	-	-	-
Totals		210	Per ITE Parking Demand	212																
Total Shared Parking Demand					0	31	66	113	150	210	211	188	174	170	177	181	166	130	87	31
Total Shared Supply					210	210	210	210	210	210	210	210	210	210	210	210	210	210	210	210
Total Shared Parking Surplus/(Deficit)					210	179	144	97	60	0	(1)	22	36	40	33	29	44	80	123	179

= Represents the peak parking demand hour of the Richfield Shoppes
 = Represents the peak hour of Anytime Fitness

Designed:	BNS
Checked:	CRF
Drawn:	BNS
As-Built Drawing:	
Revisions:	
0	DATE INITIAL SUBMITTAL

Prepared for:

**BALEO
FITNESS, INC.**

LEGEND

— RICHFIELD SHOPPES

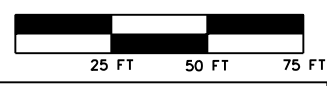

**Richfield
Shoppes**

Richfield, MN

Figure 2
Parking Stall Count

Date: 2026-03-04
 Page: 12



PARKING STALL COUNT	
STREET FACING	163
BEHIND BUILDING	47
SHOPPING CENTER TOTAL	210

4.0 Conclusion

Westwood Professional Services, Inc. (Westwood) has been retained by Baleo Fitness to prepare a Parking Analysis for the Richfield Shoppes located at the northeast quadrant of the intersection of E 66th Street and Nicollet Avenue in Richfield, MN. The Richfield Shoppes project includes Anytime Fitness replacing an existing unit within Richfield Shoppes.

This report includes an analysis of the existing parking needs for Richfield Shoppes.

This analysis was conducted utilizing the Institute of Transportation Engineering (ITE) *Parking Generation Manual, 6th Generation* and following the *City of Richfield Zoning Codes*.

FINDING:

The existing Richfield Shoppes does not meet the minimum parking demand as defined by ITE rates or minimum parking demand as defined by the City of Richfield Zoning Code when analyzing for full occupancy.

The Richfield Shoppes Peak Hour from 1:00 pm – 2:00 pm demands more parking stalls than the 210 stalls currently available for both ITE and City code when analyzing for full occupancy.

Richfield Shoppes Peak Hour (1:00 – 2:00 pm) Parking Stall Demand

Method	Peak Hour Demand	Deficit
City Code	255	45 Stalls
ITE	211	1 Stall

FINDING:

The proposed Anytime Fitness has a weekday peak hour of 5:00 pm – 6:00 pm. During this peak hour, Richfield Shoppes has a surplus of parking stalls when including the Anytime Fitness and using City and ITE rates.

Since the peak hour of Anytime Fitness does not overlap with the overall peak hour of the development, Anytime Fitness is not expected to negatively impact the parking demand at Richfield Shoppes.

Anytime Fitness Peak Hour (5:00 – 6:00 pm) Parking Stall Demand

Method	Peak Hour Demand	Surplus
City Code	200	10 Stalls
ITE	177	33 Stalls



Report Prepared By:

Jennifer Anderson, Support Services Manager

Department Director:

Jay Henthorne, Police Chief

Item for Consideration:

Consideration of the approval of a Temporary On-Sale Intoxicating Liquor license from the Fourth of July Committee for events scheduled at Veterans Memorial Park, July 4, 2026.

EXECUTIVE SUMMARY

On May 5, 2026, the City received an application for a Temporary On-Sale Intoxicating liquor license from the Fourth of July Committee. The events are scheduled to take place at Veterans Memorial Park, July 4, 2026. The fee for the Temporary On-Sale Intoxicating Liquor license has been received, along with all required documentation, including liquor liability insurance.

The Director of Public Safety has reviewed and approved the license application and sees no reason to be denied.

Alcohol will be served from 4:00 p.m. to 10:00 p.m. Alcohol will be served in an enclosed fenced-in area with monitored entrance points. Only wine and strong beer will be served. Public Safety police officers have been hired by the Fourth of July Committee to patrol the area for this event.

Food vendors will be available and the appropriate food handling and sanitation procedures will be followed.

RECOMMENDED ACTION

By Motion: Approve the request for a Temporary On-Sale Intoxicating Liquor license by the Fourth of July Committee for events scheduled at Veterans Memorial Park, July 4, 2026.

HISTORICAL CONTEXT

The applicant has satisfied the following requirements for issuance of the license: The application and required licensing fee for the Temporary On-Sale Intoxicating Liquor has been received.

Proof of liquor liability insurance has been submitted showing Incline Casualty Company affording the coverage.

A drawing of where the alcohol will be served has been submitted.

The applicant has contacted food sanitarians from the City of Bloomington to ensure proper food handling practices are followed.

EQUITABLE OR STRATEGIC CONSIDERATIONS OR IMPACTS

There are no equitable or strategic considerations or impacts.

POLICIES (RESOLUTIONS, ORDINANCES, REGULATIONS, STATUTES, ETC.)

Richfield City Code Section 1202.05 requires all applicants to comply with all the provisions of this code, as well as the provisions of Minnesota Statute Chapter 340A.

CRITICAL TIMING ISSUES

There are no critical timing issues.

FINANCIAL IMPACT

There is no financial impact.

LEGAL CONSIDERATIONS

There are no legal considerations.

ALTERNATIVE RECOMMENDATION(S)

The Council could deny the approval of the Temporary On-Sale Intoxicating Liquor license for the Fourth of July Committee. This would mean the applicant would not be able to serve wine or strong beer. However, Public Safety has not found any basis for denial.

ATTACHMENTS

None



Report Prepared By:

Mark McKinley, Administrative Assistant

Department Director:

Katie Rodriguez, City Manager

Item for Consideration:

Consider the first reading of an ordinance amending Subsection 210.01 of the City Code related to City Council salaries for 2027 and 2028.

EXECUTIVE SUMMARY

Chapter II, Section 210 of the City Code establishes the salaries of the City Council. Subsection 210.01, Subd. 5 provides that salaries of Council Members shall be reviewed by the City Council by May 1 in each year in which an election is held pursuant to Section 200 of the Code. An ordinance amending the salaries established by this section must not take effect until after the next succeeding municipal election. City Council discussed council salaries during the April 28, 2026 work session and directed staff to prepare the ordinance with no increase (0%) over the next two years for Mayor and Council Member salaries.

RECOMMENDED ACTION

By Motion: Approve the first reading of the ordinance amending Subsection 210.01 of the City Code related to City Council salaries and schedule the second reading for May 26, 2026.

HISTORICAL CONTEXT

The City has provided the same cost-of-living increase for all its employee groups for many years. The anticipated cost-of-living increase for 2027 and 2028 is unknown at this time. The cost-of-living increase for city employees in the General Pay Plan has been 3% over the last 9 years. The 2027 cost-of-living increase will be set as part of the budget process.

Since 2018, the City Council has taken the following actions related to Council wages:

2018: City Council approved that the salaries of the mayor and council members shall be increased by a percentage that was the lesser of 3.5% or the percentage increase to match the General Services Pay Plan, effective January 1, 2019, and increased by a percentage that was the lesser of 3.5% or the percentage increase in the General Services Pay Plan effective January 1, 2020. In both years, the approved increase was 3%.

2020: City Council approved that the salaries of the mayor and council members would remain the same with no increase, effective January 1, 2021. The City Council directed staff to provide an economic trigger in the ordinance for 2022 that would set the

increase to 0% if the economy has not improved, or, set the salary increase based on what is granted to employees in the Management and General Services pay plan in the previous year of 2021. The increase starting January 1, 2022, was 3%.

2022: City Council approved that the salaries of the mayor and council members would be increased to match the General Services Pay Plan, effective January 1, 2023, and that the salaries would be increased to match the General Services Pay Plan, effective January 1, 2024.

2024: City Council approved that the salaries of the mayor and council members would be increased to match the General Pay Plan, effective January 1, 2025, and that the salaries would be increased to match the General Pay Plan, effective January 1, 2026.

In the past, the City Council also reviewed and compared its salaries to Richfield’s peer cities. That information is provided below for review:

Mayor Salary (2026)		City Council Salary (2026)	
Peer City	Salary	Peer City	Salary
City of Roseville	\$10,620.00	City of Fridley	\$7,761.78
City of Fridley	\$10,688.60	City of Inver Grove Heights	\$8,200.00
City of Inver Grove Heights	\$11,400.00	City of Roseville	\$8,220.00
City of Oakdale	\$12,000.00	City of Fridley (At-Large)	\$8,779.42
City of Lino Lakes	\$12,400.00	City of Shakopee	\$9,000.00
City of Savage	\$12,487.80	City of Savage	\$9,503.36
City of Hopkins	\$12,500.00	City of Oakdale	\$9,600.00
City of Cottage Grove	\$13,351.00	City of Eagan	\$10,000.00
City of Eagan	\$13,625.00	City of Cottage Grove	\$10,057.00
City of Richfield (w/ 0% increase)	\$14,339.00	City of Lino Lakes	\$10,423.00
City of Brooklyn Center	\$14,857.00	City of Richfield (w/ 0% increase)	\$11,128.00
City of Shakopee	\$15,000.00	City of Brooklyn Center	\$11,158.00
City of Maplewood	\$17,430.40	City of Hopkins	\$12,500.00
		City of Maplewood	\$15,350.40

EQUITABLE OR STRATEGIC CONSIDERATIONS OR IMPACTS

Regular evaluation of council compensation helps ensure that pay remains reasonable and consistent with peer communities, without creating an undue financial burden for those serving in a part-time elected role.

POLICIES (RESOLUTIONS, ORDINANCES, REGULATIONS, STATUTES, ETC.)

Chapter II, Section 210 of the City Code establishes the salaries of the City Council.

CRITICAL TIMING ISSUES

Council needs to establish its salaries for 2027 and 2028 by ordinance before the next council election.

FINANCIAL IMPACT

A zero percent increase would result in no change to current City Council compensation levels for 2027 and 2028. There would be no additional impact on the General Fund beyond maintaining existing budgeted amounts.

LEGAL CONSIDERATIONS

None.

ALTERNATIVE RECOMMENDATION(S)

The City Council could vote to approve a set-amount or percentage increase in 2027 and 2028.

ATTACHMENTS

- 1. Council Salary Draft Ordinance

BILL NO. _____

**AN ORDINANCE AMENDING SECTION 210 OF THE
RICHFIELD CITY CODE PERTAINING TO
CITY COUNCIL SALARIES**

THE CITY OF RICHFIELD DOES ORDAIN:

Section 1. Subsection 210.01 of the Richfield City Code is amended as follows:

Subdivision 1. Mayor. The annual salary of the mayor as of January 1, 2024~~2026~~, is \$13,518.62 ~~\$14,339.00~~. ~~Effective January 1, 2025, the salary of the mayor shall be increased by a percentage that is equal to the percentage increase in the annual pay structure granted January 1, 2025, to the General Pay Plan.~~

Subd 2. Council. The annual salary of a member of the council as of January 1, 2024~~2026~~, is \$10,492.73 ~~\$11,128.00~~. ~~Effective January 1, 2025, the salary of a member of the council shall be increased by a percentage that is equal to the percentage increase in the annual pay structure granted January 1, 2025, to the General Pay Plan.~~

Subd. 3. Compensation adjustment. ~~There shall be no increase in the salary of the mayor or council members for the calendar years 2027 and 2028. Effective January 1, 2026, the annual salary of the mayor and a member of the council as provided in Subdivision 1 and 2 above shall receive an increase that would match the increase in the General Pay Plan granted January 1, 2026.~~

Subd. 4. Payable. Salaries of members of the Council are payable bi-weekly.

Subd. 5. Salary review. The Council shall review the salaries set by this Section by May 1 in each year in which an election is held pursuant to Section 200 of this code. An ordinance amending the salaries as established in this Section must not take effect until after the next succeeding municipal election.

Section 2. Effective Date. This ordinance becomes effective on January 1, 2027.

Passed by the City Council of the City of Richfield, Minnesota this 26th day of May 2026.

Mary B. Supple, Mayor

ATTEST:

Michelle Friedrich, City Clerk



City Council Meeting 5/12/2026

Agenda Section: Resolutions

Agenda Item: 11.a.

Report Prepared By:

Sack Thongvanh, Assistant City Manager

Department Director:

Sack Thongvanh, Assistant City Manager

Item for Consideration:

Modifying the General Services Post Employment Health Care Savings Plan and Management Post Employment Health Care Savings Plan.

EXECUTIVE SUMMARY

In 2001, the Minnesota Legislature granted the Minnesota State Retirement System (MSRS) the authority to offer a post-employment Health Care Savings Plan (HCSP) to eligible employees of the State of Minnesota and other governmental subdivisions. The Health Care Savings Plan (HCSP) is an employer-sponsored program that allows employees to set aside funds to pay for medical expenses and/or health insurance premiums after separation from employment. Employees may select from various investment options offered through the State Board of Investment. Contributions to the HCSP are tax-free, earnings accumulate tax-free, and distributions used for eligible medical expenses remain tax-free.

The primary driver for this modification is the implementation of the new Pay Structure adopted by the City Council in 2024 following the completion of the Baker Tilly Compensation and Class Study. As a result, language referencing the former pay structure has been removed and replaced with language that aligns with the new framework. Under the updated structure, employees in the General Pay Plan Grade 12 and below are included in the General Services Post Employment Health Care Savings Plan, while employees in the General Pay Plan Grade 13 and above are part of the Management Post Employment Health Care Savings Plan.

RECOMMENDED ACTION

By Motion: Adopt a resolution modifying the General Services Post Employment Health Care Savings Plan and Management Post Employment Health Care Savings Plan.

HISTORICAL CONTEXT

- Legal authority to establish a Health Care Savings Plan (HCSP) is provided under Minn. Stat. § 352.98 and applicable Internal Revenue Service rulings. The establishment of each plan, including its contribution formulas, must be negotiated when it involves a collective bargaining unit or incorporated into a personnel policy for non-union employees. Once a plan is established or modified, it must be filed with the Minnesota State Retirement System (MSRS) to

implement the new or revised plan.

- Participation in the HCSP is mandatory for all employees. In addition, the contribution amounts for or by each employee within a specific group must be uniform; however, contribution levels may differ between employee groups.
- Under state statute, HCSP plan modifications may not occur more frequently than once every two years.

EQUITABLE OR STRATEGIC CONSIDERATIONS OR IMPACTS

This change and our ability to be flexible with a benefit need will assist in retention as part of our strategic plan.

POLICIES (RESOLUTIONS, ORDINANCES, REGULATIONS, STATUTES, ETC.)

- The City of Richfield has offered this benefit to employee groups that are interested in such a mandatory plan.
- Approval of the resolution by the City Council will provide the City with authority to proceed with this modified program to the General Services Post Employment Health Care Savings Plan and Management Post Employment Health Care Savings Plan.

CRITICAL TIMING ISSUES

After City Council approval, this plan must be submitted to MSRS for filing and implementation.

FINANCIAL IMPACT

There is no cost to the City since the City makes no contribution. The plan provides a great tax savings for the participating employees and provides a tax mechanism to fund post-employment medical costs.

LEGAL CONSIDERATIONS

The plan modifications have been sent to the State for review and have received informal approval.

ALTERNATIVE RECOMMENDATION(S)

The City Council may choose not to approve this plan modification. If that occurs, the current plan would remain in effect.

ATTACHMENTS

1. HCSP-General Pay Plan-Grade 12 and Lower 5-12-26
2. HCSP-Management Pay Plan- Grade 13 and Higher 5-12-26
3. Resolution XXXXX Approving the Modification of the HCSP for General Services-General and Management Plan

Policy: ***General Services Post Employment Health Care Savings Plan***

Approved by: Richfield City Council on May 12, 2026

Effective Date: May 12, 2026

Page: 1 of 2

Plan Purpose

The City of Richfield is interested in establishing a means for eligible employees to participate in a mandatory program to help defray some of the costs of post employment health related expenses, including health insurance premiums using pre-tax dollars. Participation in the Post Employment Health Care Savings Plan, administered by the Minnesota State Retirement System (MSRS), is intended to provide an opportunity to accomplish that goal.

Post Employment Health Care Savings Plan

The Post Employment Health Care Savings Plan (HCSP) is an Employer sponsored program that allows eligible employees to:

- 1) defer payment of a portion of unused vacation and personal leave as a severance payment at the time of termination to pay for eligible health insurance premiums and/or health expenses after separation from City service: and
- 2) defer a portion of an Employee's biweekly salary for deposit into their HCSP for the payment of qualified healthcare related expenses after separation from City service.

Employees will be able to choose among several different investment options provided by the Minnesota State Board of Investment. Under the Plan, amounts contributed into the HCSP are tax-free and not subject to FICA contributions. Assets in the HCSP will accumulate tax-free and since payouts are used for qualifying medical expenses, they will also remain tax-free.

Eligibility to Participate

Participation in the **General Services HCSP** is mandatory for all employees that meet the following requirements:

1. The Employee must be a member of the **Richfield General Pay Plan, in Pay Grade 12 or lower**, at the time of termination of employment, and
2. The Employee must have been continuously employed by the City of Richfield for at least 3 consecutive years.

Contribution Formula

Mandatory participation in the HCSP shall be in accordance with, and limited to the following formulas for contributions:

I. Biweekly Contribution

1. An eligible Employee with more than **3 but less than 5 years** of service must contribute **1.0% of their base biweekly wage** to the Employee's account in the General Services HCSP. Such contributions shall not be based upon more than 40 hours per week.
2. An eligible Employee with more than **5 but less than 20 years** of service must contribute **2.00% of their base biweekly wage** to the Employee's account in the General Services HCSP. Such contributions shall not be based upon more than 40 hours per week.
3. An eligible Employee with more than **20 but less than 25 years** of service must contribute **2.25% of their base biweekly wage** to the Employee's account in the General Services HCSP. Such contributions shall not be based upon more than 40 hours per week.
4. An eligible Employee with more than **25 years** of service must contribute **2.50% of their base biweekly wage** to the Employee's account in the General Services HCSP. Such contributions shall not be based upon more than 40 hours per week.

II. Severance Contribution

1. An eligible Employee with more than 3 but less than 20 years of service will receive in severance a cash payment for the first 40 hours of accumulated but unused **Vacation Leave**. Severance based on accumulated but unused **Vacation Leave** in excess of 40 hours shall be paid as a credit to the Employee's account in the HCSP.
2. An eligible Employee with more than 20 years of service will receive in severance a cash payment for the first 80 hours of accumulated but unused **Personal Leave** and 40 hours of accumulated but unused **Vacation Leave**. Severance based on accumulated but unused **Personal Leave** in excess of 80 hours and **Vacation Leave** in excess of 40 hours shall be paid as a credit to the Employee's account in the HCSP.
3. All severance payments based upon **Personal Leave** and **Vacation Leave** are calculated as described above, by multiplying the number of hours by the applicable rate of pay at the time of termination.
4. Contributions authorized under this Plan shall continue until such time as this policy is amended or repealed by the City of Richfield.

Upon an employee's death, contributions owed but not yet paid to the HCSP will be paid to the employee's estate.

**HCSP
Administration**

The HCSP is authorized under the Internal Revenue Code and is administered by the Minnesota State Retirement System.

CITY OF RICHFIELD

City Manager

Human Resources Director

Policy: *Management Post Employment Health Care Savings Plan*

Approved by: Richfield City Council – May 12, 2026

Effective Date: May 12, 2026

Page: 1 of 2

Plan Purpose

The City of Richfield is interested in establishing a means for eligible employees to participate in a mandatory program to help defray some of the costs of post-employment health related expenses, including health insurance premiums using pre-tax dollars. Participation in the Post Employment Health Care Savings Plan, administered by the Minnesota State Retirement System (MSRS), is intended to provide an opportunity to accomplish that goal.

Post Employment Health Care Savings Plan

The Post Employment Health Care Savings Plan (HCSP) is an Employer-sponsored program that allows eligible employees to:

1. defer payment of a portion of unused vacation and personal leave as a severance payment at the time of termination to pay for eligible health insurance premiums and/or health expenses after separation from City service, and
2. defer a portion of an Employee’s bi-weekly salary for deposit into their HCSP for the payment of qualified healthcare related expenses after separation from City service.

Employees will be able to choose among several different investment options provided by the Minnesota State Board of Investment. Under the Plan, amounts contributed into the HCSP are tax-free and not subject to FICA contributions. Assets in the HCSP will accumulate tax-free and since payouts are used for qualifying medical expenses, they will also remain tax-free.

Eligibility to Participate

Participation in the **Management HCSP** is mandatory for all employees that meet the following requirements:

The Employee must meet the following requirements:

1. Employees must be a member of the **General Pay Plan, Grade 13 or higher, or the City Manager** at the time of termination of employment, and
2. The Employee must have been continuously employed by the City of Richfield for at least 3 consecutive years.

Contribution Formula

Mandatory participation in the **Management HCSP** shall be in accordance with, and limited to the following formulas for contributions:

I. Bi-weekly Contribution

1. An eligible Employee must contribute to the Employee’s account in the HCSP according to the following schedule based on total City service:

- An eligible Employee with more than **3 but less than 5 years** of service must contribute **\$45 per pay period** to the Employee's account in the Management HCSP. Such contributions shall not exceed \$45 per pay period.
- An eligible Employee with more than **5 but less than 10 years** of service must contribute **\$55 per pay period** to the Employee's account in the Management HCSP. Such contributions shall not exceed \$55 per pay period.
- An eligible Employee with more than **10 but less than 20 years** of service must contribute **\$75 per pay period** to the Employee's account in the Management HCSP. Such contributions shall not exceed \$75 per pay period.
- An eligible Employee with more than **20 but less than 25 years** of service must contribute **\$85 per pay period** to the Employee's account in the Management HCSP. Such contributions shall not exceed \$85 per pay period.
- An eligible Employee with more than **25 but less than 30 years** of service must contribute **\$95 per pay period** to the Employee's account in the Management HCSP. Such contributions shall not exceed \$95 per pay period.
- An eligible Employee with more than **30 years** of service must contribute **\$115 per pay period** to the Employee's account in the Management HCSP. Such contributions shall not exceed \$115 per pay period.

II. Severance Contribution

1. Severance shall be paid in cash for the first 80 hours of accumulated but unused **Personal Leave**. Severance based on accumulated but unused **Personal Leave** in excess of 80 hours shall be paid as a credit to the Employee's account in the **Management HCSP**.
2. Severance shall be paid in cash for the first 40 hours of accumulated but unused **Vacation Leave**. Severance based on accumulated but unused **Vacation Leave** in excess of 40 hours shall be paid as a credit to the Employee's account in the **Management HCSP**.
3. All severance payments based upon Personal & Vacation Leaves are calculated as described above, by multiplying the number of hours by the applicable rate of pay at the time of termination.

Contributions authorized under this Plan shall continue until such time as this policy is amended or repealed by the City of Richfield.

Upon an employee's death, contributions owed but not yet paid to the HCSP will be paid to the employee's estate.

**HCSP
Administration**

The HCSP is authorized under the Internal Revenue Code and is administered by the Minnesota State Retirement System.

CITY OF RICHFIELD

City Manager

Human Resources Director

RESOLUTION NO. XXXXX

Motion by:
Seconded by:

RESOLUTION MODIFYING THE GENERAL SERVICES POST EMPLOYMENT HEALTH CARE SAVINGS PLAN AND THE MANAGEMENT POST EMPLOYEMENT HEALTH CARE SAVINGS PLAN

WHEREAS, Laws of Minnesota 2001, Chapter 352.98, authorizes the Minnesota State Retirement System (MSRS) to offer a Post Employment Health Care Savings (Plan) Program to state employees, as well as other governmental subdivisions; and

WHEREAS, the Internal Revenue Service Code provided for such Plans; and

WHEREAS, the City of Richfield currently offers such Plans to eligible City employees as a tax-free method for employees to set aside money to cover the increasing cost of health insurance and medical costs after termination of public employment; and

WHEREAS, modification to the provisions of the General Services Post Employment Health Care Savings Plan and the Management Post Employment Health Care Savings Plan are allowed once every two years.

NOW, THEREFORE, BE IT RESOLVED that the City of Richfield hereby authorizes the City Manager to modify the General Services Post Employment Health Care Savings Plan and the Management Post Employment Health Care Savings Plan.

Adopted by the City Council of the City of Richfield, Minnesota on this 12th day of May 2026.

VOTING AYE

- Supple, Mary**
- Burk, Walter**
- Christensen, Sharon**
- Coleman-Woods, Rori**
- Hayford Oleary, Sean**

VOTING NAY

- Supple, Mary**
- Burk, Walter**
- Christensen, Sharon**
- Coleman-Woods, Rori**
- Hayford Oleary, Sean**

ATTEST:

Michelle Friedrich, City Clerk

Mary B. Supple, Mayor